

TABLE OF CONTENTS

VISUAL INDEX

SAFETY INFORMATION

INSTRUMENT PANEL

VEHICLE CONTROLS

AUDIO AND CONNECTIVITY

BLUETOOTH® HANDSFREELINK®

ACURALINK®

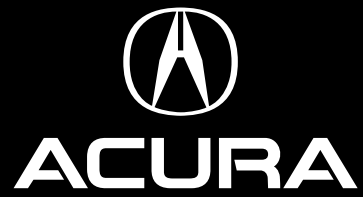

owners.acura.com (U.S.)
myacura.ca (Canada)

BOG02907
31TZ5G11
00X31-TZ5-G111

2016 Acura MDX Owner's Guide
©2015 Honda Motor Co., Ltd. — All Rights Reserved

Printed in U.S.A.



2016
OWNER'S GUIDE

NAVIGATION

DRIVING

HANDLING THE UNEXPECTED

MAINTENANCE

SPECIFICATIONS

CLIENT INFORMATION

VOICE COMMAND INDEX

INDEX

DISCLOSURES

■ California Proposition 65 Warning

WARNING: This product contains or emits chemicals known to the state of California to cause cancer and birth defects or other reproductive harm.

■ California Perchlorate Contamination Prevention Act

The airbags, seat belt tensioners, and CR-type batteries in this vehicle may contain perchlorate materials — special handling may apply. See www.dtsc.ca.gov/hazardouswaste/perchlorate/ for more information.

■ Devices That Emit Radio Waves

The following products and systems on your vehicle emit radio waves when in operation:

- AcuraLink®
- Audio system
- Blind Spot Information system
- Bluetooth® Audio
- Bluetooth® HandsFreeLink®
- Collision Mitigation Braking System™
- HomeLink® Universal Transceiver
- Immobilizer system
- Remote transmitter
- Keyless Access System
- Tire Pressure Monitoring System

Each of the above complies with the appropriate requirements or the required standards of FCC (Federal Communications Commission) and Industry Canada, described below:

As required by the FCC:

This device complies with Part 15 of the FCC rules. Operation is subject to the following two conditions: (1) This device may not cause harmful interference, and (2) this device must accept any interference received, including interference that may cause undesired operation.

Changes or modifications not expressly approved by the party responsible for compliance could void the user's authority to operate the equipment.

As required by Industry Canada:

This device complies with Industry Canada Standard RSS-Gen/210/310. Operation is subject to the following two conditions: (1) this device may not cause interference, and (2) this device must accept any interference, including interference that may cause undesired operation of the device.

■ Event Data Recorders

This vehicle is equipped with an event data recorder (EDR). The main purpose of an EDR is to record, in certain crash or near crash-like situations, such as an air bag deployment or hitting a road obstacle, data that will assist in understanding how a vehicle's systems performed. **The EDR is designed to record data related to vehicle dynamics and safety systems for a short period of time, typically 30 seconds or less. The EDR in this vehicle is designed to record such data as:**

- How various systems in your vehicle were operating;
- Whether or not the driver and passenger safety belts were buckled/ fastened;
- How far (if at all) the driver was depressing the accelerator and/or brake pedal; and,
- How fast the vehicle was traveling.

These data can help provide a better understanding of the circumstances in which crashes and injuries occur. NOTE: EDR data are recorded by your vehicle only if a non-trivial crash situation occurs; no data are recorded by the EDR under normal driving conditions and no personal data (e.g., name, gender, age, and crash location) are recorded. However, other parties, such as law enforcement, could combine the EDR data with the type of personally identifying data routinely acquired during a crash investigation.

To read data recorded by an EDR, special equipment is required, and access to the vehicle or the EDR is needed. In addition to the vehicle manufacturer, other parties such as law enforcement that have the special equipment can read the information if they have access to the vehicle or the EDR.

The data belong to the vehicle owner and may not be accessed by anyone else except as legally required or with the permission of the vehicle owner.

■ Service Diagnostic Recorders

This vehicle is equipped with service-related devices that record information about powertrain performance. The data can be used to verify emissions law requirements and/or help technicians diagnose and solve service problems. It may also be combined with data from other sources for research purposes, but it remains confidential.

INTRODUCTION

This Owner's Guide is intended to help you quickly get acquainted with your **2016 Acura MDX**. It provides basic information and instructions on technology and convenience features, as well as emergency procedures and how to get assistance.

This guide is for vehicles sold in the United States and Canada. It covers all MDX models, so you may find descriptions of features and equipment that are not in your vehicle. Images throughout this guide are from U.S. vehicles and represent features and equipment that are available on some, but not all, models.

This guide is not intended to be a substitute for the Owner's Manual. The Owner Information CD enclosed in your glove box kit includes the Owner's Manual, Navigation Manual, and vehicle and tire warranties in electronic format. This information can be viewed on a computer (PC or Mac platform) and saved or printed for your reference. You can also visit owners.acura.com (U.S.) or myacura.ca (Canada) to view the complete and most current information.

If you are the first registered owner of your vehicle, you may request a complimentary printed copy of the Owner's Manual, Navigation Manual, or Vehicle Warranty up to six months after vehicle purchase. To request a copy, visit owners.acura.com (U.S.) or myacura.ca (Canada) and create or log in to your account. In Canada, please request a copy from your Acura dealer.

American Honda Motor Company strives to be proactive in protecting our environment and natural resources. By using electronic delivery for a considerable portion of the information typically found in a vehicle owner's manual, we are further reducing our impact on the environment.

Acura Total Luxury Care Roadside Assistance

Your Acura TLC Roadside Assistance representative is here to help you 24 hours a day, 7 days a week. Under your 4-year/50,000-mile (80,000-km) warranty, the following benefits are available:

- Towing services — full cost of towing to the closest Acura dealer
- Roadside assistance — jump starting, fuel delivery, lockout, and flat tire
- Trip planning — detailed trip routing, emergency services, and more

Call (800) 594-8500 (U.S.) or (800) 565-7587 (Canada)

Acura Client Relations

Your authorized Acura dealer should be able to answer any questions you have about your vehicle. However, if you are dissatisfied with the information you receive, you can call Acura Client Relations (see page 149).

Call (800) 382-2238 (U.S.) or (888) 922-8729 (Canada)

TABLE OF CONTENTS

VISUAL INDEX.....	1	Seat Heaters and Ventilation*	50
Steering Wheel and Nearby Controls.....	1	Customized Features.....	51
Dashboard and Ceiling Controls.....	2	AUDIO AND CONNECTIVITY	52
SAFETY INFORMATION.....	3	Basic Audio Operation.....	52
Important Safety Information.....	3	On-Demand Multi-Use Display (ODMD).....	54
Seat Belts	5	FM/AM Radio.....	55
Airbags.....	9	SiriusXM® Radio.....	56
Child Safety	15	Compact Disc (CD) or USB Flash Drive.....	57
Safety Label Locations	22	Hard Disc Drive (HDD) Audio*	58
Reporting Safety Defects.....	23	iPod®.....	59
INSTRUMENT PANEL	24	Bluetooth® Audio.....	60
Malfunction Indicators.....	24	Pandora®.....	61
Condition Indicators.....	26	AcuraLink featuring Aha™.....	62
On/Off Indicators	27	Rear Entertainment System (RES)*	63
Multi-Information Display	28	BLUETOOTH® HANDSFREELINK®...67	
VEHICLE CONTROLS.....	29	Basic HFL Operation	67
Using the Remote Transmitter.....	29	Pairing a Phone.....	69
Keyless Access System.....	30	Making a Call	70
Power Tailgate Operation	31	SMS Text Messaging and E-Mail ...	73
Door Operation from Inside the Vehicle	32	Siri™ Eyes Free	74
Power Window Operation	33	ACURALINK®*	75
Power Moonroof Operation	34	AcuraLink Messages.....	75
Interior and Exterior Lights.....	35	Subscription Features.....	76
One-Touch Turn Signal	36	NAVIGATION*	77
Wiper Operation	37	Basic Navigation Operation	77
Adjusting the Seats.....	39	Entering a Destination	80
Adjusting the Mirrors.....	42	Routing	82
Adjusting the Steering Wheel	43	DRIVING.....	84
Driving Position Memory System ...	43	Before Driving.....	84
Rear Seats.....	44	Maximum Load Limit.....	86
HomeLink® Garage Opener.....	46	Towing a Trailer	88
Climate Control System.....	47		

*if equipped

VISUAL INDEX

Quickly locate items in the vehicle's interior.

Steering Wheel and Nearby Controls

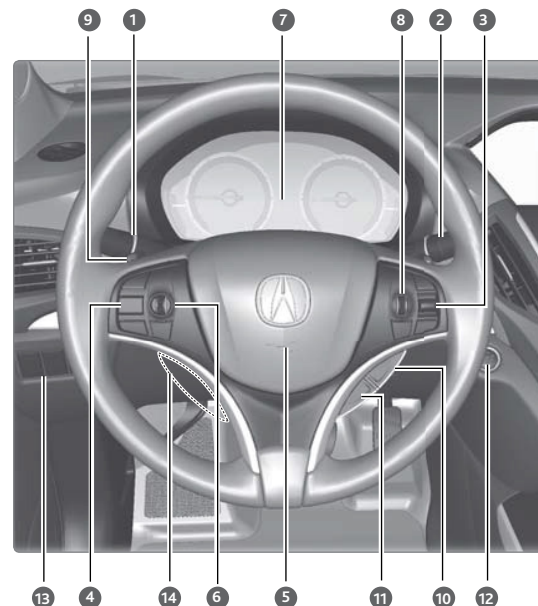

- 1 Lights/turn signals p. 35, 36
- 2 Wipers/washers p. 37
- 3 Cruise control/Adaptive Cruise Control (ACC) with Low Speed Follow* buttons p. 99, 96
- 4 Voice recognition/*Bluetooth*® HandsFreeLink® buttons p. 67
- 5 Horn
- 6 Audio controls p. 53
- 7 Instrument panel p. 24
Multi-information display p. 28
- 8 Right selector wheel p. 28
TRIP button p. 28
- 9 Paddle shifters p. 95
- 10 Distance (ACC) button* p. 100
- 11 Lane Keeping Assist System (LKAS) button* p. 106
- 12 ENGINE START/STOP button p. 93
- 13 Vehicle Stability Assist (VSA®) OFF button p. 97
Lane Departure Warning (LDW) button* p. 105
Road Departure Mitigation (RDM) button* p. 107
Parking sensor button* p. 109
Collision Mitigation Braking System™ OFF button* p. 103
Heated windshield button* p. 49
Headlight washer button* p. 35
- 14 Heated steering wheel button* p. 49

*if equipped

Remote Engine Start*.....	92	Emergency Engine Stop.....	116
Starting to Drive.....	93	Overheating.....	117
Shifting.....	94	Tire Pressure Monitoring System (TPMS).....	118
Auto Idle Stop*.....	96	Changing a Flat Tire.....	120
Integrated Dynamics System (IDS).....	97	Tire Repair Kit*.....	124
Vehicle Stability Assist (VSA®), aka Electronic Stability Control (ESC) System.....	97	Fuse Locations.....	125
Braking.....	98	Emergency Towing.....	129
Cruise Control*.....	99	MAINTENANCE.....	130
Adaptive Cruise Control (ACC) with Low Speed Follow*.....	100	Safety Precautions.....	130
Forward Collision Warning (FCW) with Pedestrian Detection*.....	102	Maintenance Minder™.....	131
Collision Mitigation Braking System™ (CMBS™)*.....	103	Under the Hood.....	133
Lane Departure Warning (LDW)*.....	105	Engine Oil.....	134
Lane Keeping Assist System (LKAS)*.....	106	Engine Coolant.....	136
Road Departure Mitigation (RDM)*.....	107	Window Washer Fluid.....	137
Blind Spot Information (BSI)*.....	108	Checking the Battery.....	137
Parking Sensor System*.....	109	Changing Wiper Blades.....	138
Multi-View Rear Camera*.....	110	Tire Information.....	140
Rear Cross Traffic Monitor*.....	111	Tire Labeling.....	143
Surround View Camera*.....	112	DOT Tire Quality Grading.....	144
Refueling.....	114	Testing of Readiness Codes.....	146
HANDLING THE UNEXPECTED...115		SPECIFICATIONS.....	147
Keyless Access Remote Battery Strength.....	115	CLIENT INFORMATION.....	148
Jump Starting.....	115	Frequently Asked Questions/ Troubleshooting.....	148
		Contact Us.....	149
		Acura Total Luxury Care Roadside Assistance.....	150
		Warranty Coverages.....	150
		VOICE COMMAND INDEX.....	151
		INDEX.....	153

*if equipped

Dashboard and Ceiling Controls

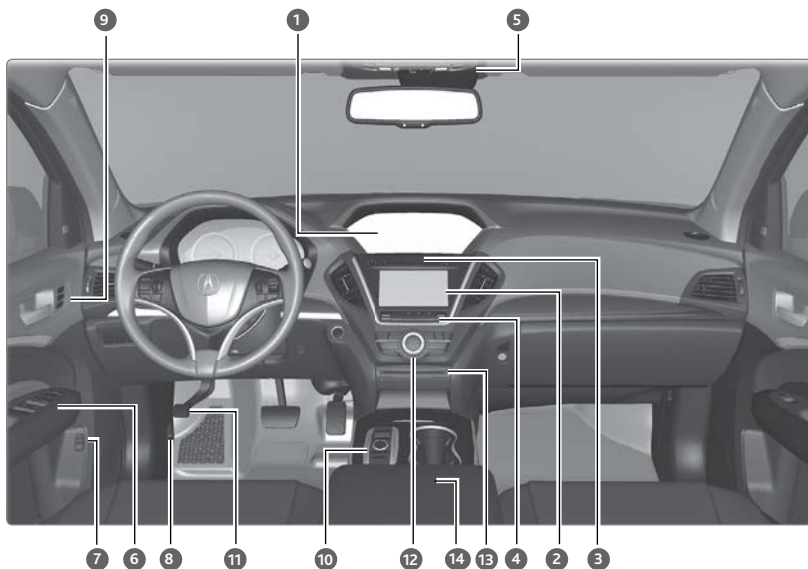

- | | |
|--|---|
| <ul style="list-style-type: none"> 1 Color information display 2 On-Demand Multi-Use Display (ODMD) p. 54 3 Hazard warning button 4 Climate control buttons p. 47 5 Moonroof switch p. 34 6 Power window switches p. 33 7 Power tailgate button p. 31 | <ul style="list-style-type: none"> 8 Hood release handle p. 133 9 Driving Position Memory System buttons p. 43 10 Integrated Dynamics System (IDS) button p. 97 11 Parking brake p. 98 12 Audio/phone/navigation/Surround View Camera* buttons p. 50, 65, 75, 105 13 Rear entertainment system* p. 63 14 (inside center console) USB port p. 53 15 Auxiliary input jack p. 53 |
|--|---|

*if equipped

SAFETY INFORMATION

Your safety—and the safety of others—is very important, and operating this vehicle safely is an important responsibility. While we strive to help you make informed decisions about safety, it is not practical or possible to warn you about all the hazards associated with operating or maintaining your vehicle. Therefore, you must use your own good judgment.

Important Safety Information

This guide explains many of your vehicle's safety features and how to use them. Please read this information carefully. Following the instructions below will also help to keep you and your passengers safe.

■ Important Safety Precautions

- Always wear your seat belt.
- Secure all children in the proper restraint system.
- Be aware of airbag hazards.
- Don't drink and drive.
- Pay appropriate attention to the task of driving safely.
- Control your speed.
- Keep your vehicle in safe condition.

Engaging in cell phone conversation or other activities that keep you from paying close attention to the road, other vehicles, and pedestrians could lead to a crash. Remember, situations can change quickly, and only you can decide when it is safe to divert some attention away from driving.

■ Important Handling Information

Your vehicle has a higher ground clearance than a passenger vehicle designed for use only on pavement. Higher ground clearance has many advantages for off-highway driving. It allows you to travel over bumps, obstacles, and rough terrain. It also provides good visibility so you can anticipate problems earlier.

These advantages come at some cost. Because your vehicle is taller and rides higher off the ground, it has a higher center of gravity, making it more susceptible to tipping or rollover if you make abrupt turns. Utility vehicles have a significantly higher rollover rate than other types of vehicles. In a rollover crash, an unbelted person is significantly more likely to die than a person wearing a seat belt. As a reminder, make sure you and your passengers always wear seat belts.

⚠️WARNING

Improperly operating this vehicle on or off pavement can cause a crash or rollover in which you and your passengers can be seriously injured or killed.

- Follow all instructions and guidelines in this guide.
- Keep your speed low, and don't drive faster than conditions permit.

■ Safety Messages

When you see the following messages throughout this guide, pay close attention.

⚠️DANGER You WILL be KILLED or SERIOUSLY HURT if you don't follow instructions.

⚠️WARNING You CAN be KILLED or SERIOUSLY HURT if you don't follow instructions.

⚠️CAUTION You CAN be HURT if you don't follow instructions.

NOTICE This information is intended to help you avoid damage to your vehicle, other property, or the environment.

■ Carbon Monoxide Gas

The engine exhaust from this vehicle contains carbon monoxide, a colorless, odorless, and highly toxic gas. As long as you properly maintain your vehicle and follow the instructions set forth below, you will not accumulate dangerous levels of carbon monoxide gas in the vehicle interior.

Have the exhaust system inspected for leaks whenever:

- The exhaust system is making an unusual noise.
- The exhaust system may have been damaged.
- The vehicle is raised for an oil change.

When you operate a vehicle with the tailgate open, airflow can pull exhaust gas into the interior and create a hazardous condition. If you must drive with the tailgate open, open all the windows and set the climate control system as shown below.

1. Select the fresh air mode.
2. Select the **the** mode.
3. Set the fan speed to high.
4. Set the temperature control to a comfortable setting.

Adjust the climate control system in the same manner if you sit in your parked vehicle with the engine running.

⚠️WARNING

Carbon monoxide gas is toxic. Breathing it can cause unconsciousness and even kill you.

Avoid any enclosed areas or activities that expose you to carbon monoxide.

An enclosed area such as a garage can quickly fill up with carbon monoxide gas. Do not run the engine with the garage door closed. Even when the garage door is open, drive out of the garage immediately after starting the engine.

Seat Belts

A seat belt is your best protection in all types of collisions. Airbags are designed to supplement seat belts, not replace them. So even though your vehicle is equipped with airbags, make sure you and your passengers always wear your seat belts and wear them properly.

■ Lap/Shoulder Seat Belts

All seven seating positions are equipped with lap/shoulder seat belts with emergency locking retractors. In normal driving, the retractor lets you move freely while keeping some tension on the belt. During a collision or sudden stop, the retractor locks to restrain your body. The front passenger's, second-row, and third-row seat belts also have a lockable retractor for use with child seats.

The front seats are equipped with automatic seat belt tensioners to enhance safety. The tensioners automatically tighten the front seat belts during a moderate-to-severe front collision, sometimes even if the collision is not severe enough to inflate the front airbags or the driver's knee airbag.

■ Proper Use of Seat Belts

Follow these guidelines for proper use:

- All occupants should sit upright, well back in the seat, and remain in that position for the duration of the trip. Slouching and leaning reduces the effectiveness of the belt and can increase the chance of serious injury in a crash.
- Never place the shoulder part of a lap/shoulder seat belt under your arm or behind your back. This could cause very serious injuries in a crash.
- Two people should never use the same seat belt. If they do, they could be very seriously injured in a crash.
- Do not put any accessories on the seat belts. Devices intended to improve comfort or reposition the shoulder part of a seat belt can reduce the protective capability and increase the chance of serious injury in a crash.
- No one should sit in a seat with an inoperative seat belt or one that does not appear to be working correctly. Using a seat belt that is not working properly may not protect the occupant in a crash. Have a dealer check the belt as soon as possible.

⚠️WARNING

Not wearing a seat belt properly increases the chance of a serious injury or death in a crash, even though your vehicle has airbags.

Be sure you and your passengers always wear seat belts and wear them properly.

■ Seat Belt Inspection

Regularly check the condition of your seat belts as follows:

- Pull each belt out fully, and look for frays, cuts, burns, and wear.
- Check that the latches work smoothly and the belts retract easily. If a belt does not retract easily, cleaning the belt may correct the problem. Only use a mild soap and warm water. Do not use bleach or cleaning solvents. Make sure the belt is completely dry before allowing it to retract.

Any belt that is not in good condition or working properly will not provide proper protection and should be replaced as soon as possible.

A belt that has been worn during a crash may not provide the same level of protection in a subsequent crash. Have your seat belts inspected by a dealer after any collision.

⚠️WARNING

Not checking or maintaining seat belts can result in serious injury or death if the seat belts do not work properly when needed.

Check your seat belts regularly and have any problem corrected as soon as possible.

■ Fastening a Seat Belt

Adjust your seat to the proper position (see page 39), and then follow the below steps.

1. Pull the seat belt out slowly.
2. Insert the latch plate into the buckle, then tug on the belt to make sure the buckle is secure. Make sure that the belt is not twisted or caught on anything.



On models with CMBS™, the front seat belts retract automatically.

3. Position the lap part of the belt as low as possible across your hips, then pull up on the shoulder part of the belt so the lap part fits snugly. This lets your strong pelvic bones take the force of a crash and reduces the chance of internal injuries.

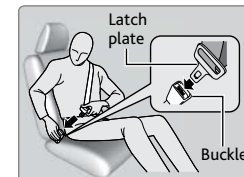

4. If necessary, pull up on the belt again to remove any slack, then make sure that the belt rests across the center of your chest and over your shoulder. This spreads the forces of a crash over the strongest bones in your upper body.



To release the belt, push the red PRESS button then guide the belt by hand until it has retracted completely.

⚠️WARNING

Improperly positioning the seat belts can cause serious injury or death in a crash.

Make sure all seat belts are properly positioned before driving.

■ Adjusting the Shoulder Anchor

The front seats have adjustable shoulder anchors to accommodate taller and shorter occupants.

1. Move the anchor up and down while holding the release button.
2. Position the anchor so that the belt rests across the center of your chest and over your shoulder.



■ Seat Belt with Detachable Anchor

The seat belt for the second-row center seat is located in the ceiling.

1. Pull out the seat belt's small latch plate and the latch plate from each holding slot in the ceiling.
2. Line up the triangle marks on the small latch plate and anchor buckle. Make sure the seat belt is not twisted. Attach the belt to the anchor buckle.
3. Insert the latch plate into the buckle. Properly fasten the seat belt the same way you fasten the lap/shoulder seat belt.

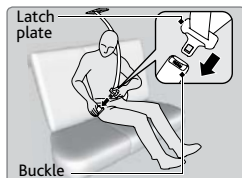
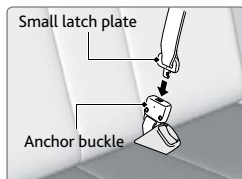
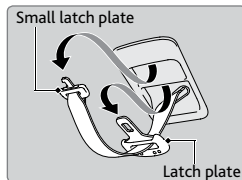

To unlatch the detachable anchor, insert the latch plate into the slot on the side of the anchor buckle.

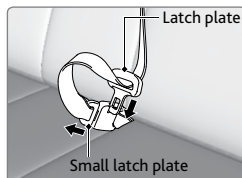

⚠️ WARNING

Using the seat belt with the detachable anchor unlatched increases the chance of serious injury or death in a crash.

Before using the seat belt, make sure the detachable anchor is correctly latched.

Airbags

Your vehicle is equipped with several types of airbags: front airbags, driver's knee airbag, side airbags, and side curtain airbags.

■ Front Airbags (SRS)

The front SRS airbags inflate in a moderate-to-severe frontal collision to help protect the head and chest of the driver and/or front passenger. They are housed in the center of the steering wheel for the driver, and in the dashboard for the front passenger. Both airbags are marked **SRS AIRBAG**.

SRS (Supplemental Restraint System) indicates that the airbags are designed to supplement seat belts, not replace them. Seat belts are the occupant's primary restraint system.

■ Driver's Knee Airbag

The driver's knee SRS airbag inflates with the driver's front airbag in a moderate-to-severe frontal collision to help keep the driver in the proper position and to help maximize the benefit provided by the vehicle's other safety features.

■ Advanced Airbags

Your front airbags have advanced features to help reduce the likelihood of airbag-related injuries to smaller occupants.

The driver's advanced front airbag system includes a seat position sensor. If the seat is too far forward, the airbag inflates with less force, regardless of the severity of the impact.

If there is a problem with the driver's seat position sensor, the SRS indicator will come on and the airbag will inflate with full (normal) force, regardless of the driver's seating position.

The passenger's advanced front airbag system has weight sensors. Although Acura recommends against carrying an infant or small child in front, if the sensors detect the weight of a child (up to 65 lbs or 29 kg), the system will automatically turn off the passenger's front airbag.

For both advanced front airbags to work properly:

- Do not spill any liquid on or under the seats.
- Do not put any object under the passenger's seat.
- Make sure any objects are positioned properly on the floor. Improperly positioned objects can interfere with the advanced airbag sensors.
- All occupants should sit upright and wear their seat belts properly.
- Do not place any cover over any part of the passenger side dashboard.

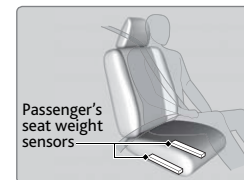
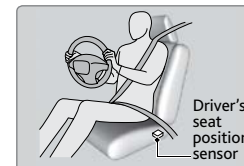

■ Side Airbags

The side airbags help protect the upper torso and pelvis of the driver or a front passenger during a moderate-to-severe side impact. They are housed in the outside edge of the driver's and front passenger's seat-backs. Both are marked **SIDE AIRBAG**.

■ Side Curtain Airbags

Side curtain airbags help protect the head and torso of the driver and passengers in outer seating positions during a moderate-to-severe side impact. The side curtain airbags equipped in this vehicle are also designed to help reduce the likelihood of partial and complete ejection of vehicle occupants through side windows in crashes, particularly rollover crashes.

The side curtain airbags are located in the ceiling above the side windows on both sides of the vehicle.

The side curtain airbags are designed to deploy in a rollover or moderate-to-severe side impact. If the SRS control unit senses that your vehicle is about to roll over, it immediately deploys both side curtain airbags and activates both front seat belt tensioners. If the impact is on the passenger's side, the passenger's side curtain airbag will inflate even if there are no occupants on that side of the vehicle.

To get the best protection from the side curtain airbags, occupants should wear their seat belts properly and sit upright and well back in their seats.

Do not attach any objects to the side windows or roof pillars, as they can interfere with the proper operation of the side curtain airbags.

When side curtain airbags deploy in a frontal collision

One or both side curtain airbags may inflate in a moderate-to-severe angled frontal collision. In this case, the side curtain airbags will deploy slightly after the front airbags.

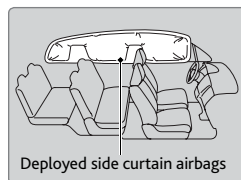
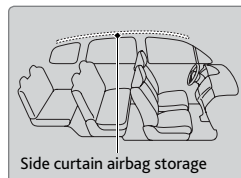

■ Important Facts About Your Airbags

Always wear your seat belt properly, and sit upright and as far back from the steering wheel as possible while allowing full control of the vehicle. A front passenger should move their seat as far back from the dashboard as possible.

Do not place hard or sharp objects between yourself and a front airbag.

Carrying hard or sharp objects on your lap, or driving with a pipe or other sharp object in your mouth, can result in injuries if your front airbag inflates.

Do not attach or place objects on the front and driver's knee airbag covers.

Objects on the covers marked SRS AIRBAG could interfere with the proper operation of the airbags or be propelled inside the vehicle and hurt someone if the airbags inflate.

Do not attach accessories on or near the side airbags. They can interfere with the proper operation of the airbags, or hurt someone if an airbag inflates.

Do not attach any objects to the side windows or roof pillars. They can interfere with the proper operation of the side curtain airbags.

Do not cover or replace the front seat-back covers. This can prevent your side airbags from properly deploying during a side impact.

⚠ WARNING

An open glove box can cause serious injury to your passenger in a crash, even if the passenger is wearing the seat belt.

Always keep the glove box closed while driving.

■ Airbag System Indicators

If a problem occurs in the airbag system, the SRS indicator comes on and a message appears on the multi-information display.

SRS (Supplemental Restraint System) Indicator

If the indicator comes on at any other time besides vehicle start-up, or does not come on at all, have the system checked by a dealer as soon as possible. If you don't, your airbags and seat belt tensioners may not work properly when they are needed.



⚠ WARNING

Ignoring the SRS indicator can result in serious injury or death if the airbag systems or tensioners do not work properly.

Have your vehicle checked by a dealer as soon as possible if the SRS indicator alerts you to a possible problem.

Passenger Airbag Off Indicator

The indicator comes on to alert you that the front passenger's front airbag has been turned off. This occurs when the front passenger's weight sensors detect 65 lbs (29 kg) or less, the weight of an infant or small child, on the seat.

Infants and small children should always ride properly restrained in a back seat.

Objects placed on the front passenger's seat can also cause the indicator to come on.

If the front passenger's seat is empty, the passenger's front airbag will not deploy and the indicator will not come on.

If the indicator comes on with no occupant or objects in the front passenger's seat, something may be interfering with the weight sensors, such as:

- An object hanging on the seat or in the seat-back pocket.
- A child seat or other object pressing against the rear of the seat-back.
- A rear passenger pushing or pulling on the back of the front passenger's seat.
- The front seat or seat-back is forced against an object on the seat or floor behind it.
- An object placed under the front passenger's seat.

If none of these conditions exist, have your vehicle checked by a dealer as soon as possible.

The passenger airbag off indicator may go on and off repeatedly if the total weight on the seat is near the airbag cutoff threshold.



Airbag System Components

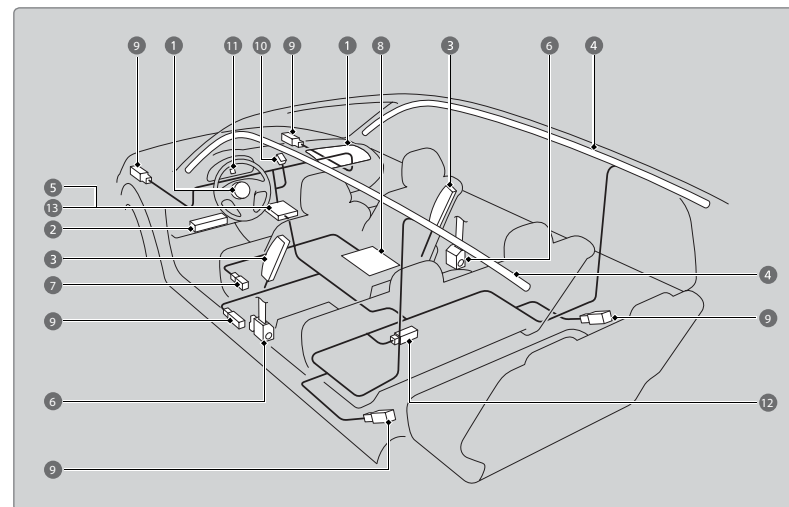

- 1 Two SRS (Supplemental Restraint System) front airbags. The driver's airbag is stored in the center of the steering wheel; the front passenger's airbag is stored in the dashboard. Both are marked **SRS AIRBAG**.
- 2 Driver's knee airbag. The knee airbag is stored under the steering column. It is marked **SRS AIRBAG**.
- 3 Two side airbags, one for the driver and one for the front passenger. The airbags are stored in the outer edges of the seatbacks. Both are marked **SIDE AIRBAG**.
- 4 Two side curtain airbags, one for each side of the vehicle. The airbags are stored in the ceiling, above the side windows. The front and rear pillars are marked **SIDE CURTAIN AIRBAG**.
- 5 An electronic control unit that continually monitors and can record information about the sensors, the airbag activators, the seat belt tensioners, and driver and front passenger seat belt use when the vehicle is on.
- 6 Automatic front seat belt tensioners. The driver's and front passenger's seat belts incorporate sensors that detect whether or not they are fastened. On models with CMBS™, the front seat belt tensioners also include the e-pretensioners.
- 7 A driver's seat position sensor. If the seat is too far forward, the airbag will inflate with less force.
- 8 Weight sensors in the front passenger's seat. The front passenger's airbag will be turned off if the weight on the seat is 65 lbs (29 kg) or less (the weight of an infant or small child).

- 9 Impact sensors that can detect a moderate-to-severe front or side impact.
- 10 An indicator on the dashboard that alerts you that the front passenger's front airbag has been turned off.
- 11 An indicator on the instrument panel that alerts you to a possible problem with the airbag system or seat belt tensioners.
- 12 Safing sensor
- 13 A rollover sensor that detects whether the vehicle is about to roll over.

■ Airbag Care

You do not need to, and should not, perform any maintenance on or replace any airbag system components yourself. However, you should have your vehicle inspected by a dealer in the following situations:

When the airbags have deployed

If an airbag has inflated, the control unit and other related parts must be replaced. Similarly, once an automatic seat belt tensioner has been activated, it must be replaced.

When the vehicle has been in a moderate-to-severe collision

Even if the airbags did not inflate, have your dealer inspect the following: the driver's seat position sensor, weight sensors in the passenger's seat, front seat belt tensioners, and each seat belt that was worn during the crash.

Do not remove or modify a front seat without first consulting a dealer

This would likely disable the driver's seat position sensor or the weight sensors in the passenger's seat. If it is necessary to remove or modify a front seat to accommodate a person with disabilities, contact an Acura dealer. For U.S. vehicles, call Acura Client Relations at (800) 382-2238. For Canadian vehicles, call Acura Client Services at (888) 922-8729.

Child Safety

Each year, many children are injured or killed in vehicle crashes because they are either unrestrained or not properly restrained. In fact, vehicle collisions are the number one cause of death of children ages 12 and under.

The National Highway Traffic Safety Administration and Transport Canada recommend that all children ages 12 and under be properly restrained in a rear seat. Some states or provinces/territories have laws restricting where children may ride.

To reduce the number of child deaths and injuries, every state, Canadian province, and territory requires that infants and children be properly restrained when they ride in a vehicle.

■ Protecting Child Passengers—Important Considerations

- An inflating front or side airbag can injure or kill a child sitting in the front passenger's seat.
- A child in the front passenger's seat is more likely to interfere with the driver's ability to safely control the vehicle.
- Statistics show that children of all sizes and ages are safer when they are properly restrained in a rear seat.
- Any child who is too small to wear a seat belt correctly must be restrained in an approved child seat that is properly secured to the vehicle using either the lap belt portion of the lap/shoulder belt or the lower anchors of the LATCH system.
- Never hold a child on your lap because it is impossible to protect them in the event of a collision.
- Never put a seat belt over yourself and a child. During a crash, the belt would likely press deep into the child and cause serious or fatal injuries.
- Never let two children use the same seat belt. Both children could be very seriously injured in a crash.
- Do not allow children to operate the doors, windows, or seat adjustments.
- Do not leave children in the vehicle unattended, especially in hot weather when the inside of the vehicle can get hot enough to kill them. They could also activate vehicle controls, causing it to move unexpectedly.

WARNING

Children who are unrestrained or improperly restrained can be seriously injured or killed in a crash.

Any child too small for a seat belt should be properly restrained in a child seat. A larger child should be properly restrained with a seat belt, using a booster seat if necessary.

⚠ WARNING

Allowing a child to play with a seat belt or wrap one around their neck can result in serious injury or death.

Instruct children not to play with any seat belt and make sure any unused seat belt a child can reach is buckled, fully retracted, and locked.

■ Protecting Infants

An infant must be properly restrained in a rear-facing, reclining child seat until the infant reaches the seat manufacturer's weight or height limit for the seat, and the infant is at least one year old. Many experts recommend use of a rear-facing seat for a child up to two years old if the child's height and weight are appropriate for a rear-facing seat.

Child seats must be placed and secured in a rear seating position. Rear-facing child seats should never be installed in a forward-facing position.

When properly installed, a rear-facing child seat may prevent the driver or a front passenger from moving their seat all the way back, or from locking their seat-back in the desired position. If this occurs, we recommend that you install the child seat directly behind the front passenger's seat, move the seat as far forward as needed, and leave it unoccupied. Or, you may wish to get a smaller rear-facing child seat.

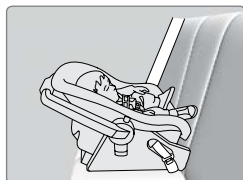
**⚠ WARNING**

Placing a rear-facing child seat in the front seat can result in serious injury or death during a crash.

Always place a rear-facing child seat in the rear seat, not the front.

■ Protecting Smaller Children

If a child is at least one year old and within the weight range indicated by the child seat manufacturer, the child should be properly restrained in a firmly secured forward-facing child seat.

We strongly recommend placing a forward-facing child seat in a rear seating position.

Placing a forward-facing child seat in the front seat can be hazardous, even with advanced front airbags that automatically turn the passenger's front airbag off. A rear seat is the safest place for a child.

**⚠ WARNING**

Placing a forward-facing child seat in the front seat can result in serious injury or death if the front airbag inflates.

If you must place a forward-facing child seat in front, move the vehicle seat as far back as possible, and properly restrain the child.

■ Selecting a Child Seat

Most child seats are LATCH-compatible (Lower Anchors and Tethers for Children). Some have a rigid-type connector, while others have a flexible-type connector. Both are equally easy to use. Some existing and previously owned child seats can only be installed using the seat belt. Whichever type you choose, follow the child seat manufacturer's use and care instructions as well as the instructions in this manual. Proper installation is key to maximizing your child's safety.

In seating positions and vehicles not equipped with LATCH, a LATCH-compatible child seat can be installed using the seat belt and a top tether for added security. This is because all child seats are required to be designed so that they can be secured with a lap belt or the lap part of a lap/shoulder belt. In addition, the child seat manufacturer may advise that a seat belt be used to attach a LATCH-compatible seat once a child reaches a specified weight. Please read the child seat owner's manual for proper installation instructions.

Important considerations when selecting a child seat

Make sure the child seat meets the following three requirements:

- The child seat is the correct type and size for the child.
- The child seat is the correct type for the seating position.
- The child seat is compliant with Federal Motor Vehicle Safety Standard 213 or Canadian Motor Vehicle Safety Standard 213.

■ Installing a LATCH-Compatible Child Seat

A LATCH-compatible child seat can be installed in the second-row seats. A child seat is attached to the lower anchors with either the rigid or flexible type of connectors.

1. Locate the lower anchors under the marks.
2. Place the child seat on the vehicle seat, then attach the child seat to the lower anchors according to the instructions that came with the child seat. Make sure that the lower anchors are not obstructed by the seat belt or any other object.

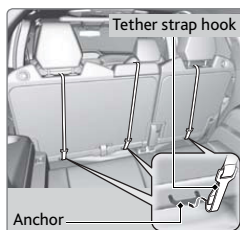
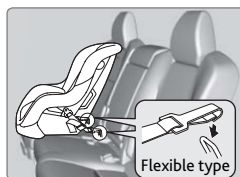
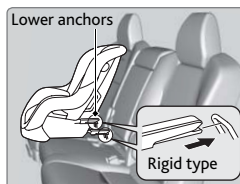

Outer seats: Raise the head restraint to its highest position, then route the tether strap between the head restraint legs, and secure the tether strap hook onto the anchor.

Center seat: Lower the center head restraint to its lowest position, then route the tether strap over the top of the head restraint and secure the tether strap hook onto the anchor.

3. Make sure the strap is not twisted. Tighten the tether strap as instructed by the child seat manufacturer.
4. Make sure the child seat is firmly secured by rocking it forward and back and side to side; little movement should be felt.
5. Make sure any unused seat belt that a child can reach is buckled, the lockable retractor is activated, and the belt is fully retracted and locked.

■ Installing a Child Seat with a Lap/Shoulder Seat Belt

1. Place the child seat on the vehicle seat.
2. Route the seat belt through the child seat according to the seat manufacturer's instructions, and insert the latch plate into the buckle. Insert the latch plate fully until it clicks.
3. Slowly pull the shoulder part of the belt all the way out until it stops. This activates the lockable retractor.
4. Let the seat belt completely wind up into the retractor, then try to pull it out to make sure the retractor is locked. If you are able to pull the shoulder belt out, the lockable retractor is not activated. Pull the seat belt all the way out, and repeat steps 3 – 4.
5. Grab the shoulder part of the seat belt near the buckle, and pull up to remove any slack from the lap part of the belt. When doing this, place your weight on the child seat and push it into the vehicle seat.
6. Make sure the child seat is firmly secured by rocking it forward and back and side to side; little movement should be felt.
7. Make sure any unused seat belt that a child can reach is buckled, the lockable retractor is activated, and the belt is fully retracted and locked.

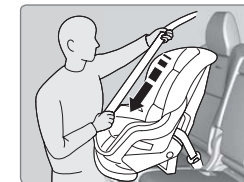

To deactivate a lockable retractor, release the buckle and allow the seat belt to wind up all the way.

■ Adding Security with a Tether

A tether anchorage point is provided behind each second- and third-row seating position. A child seat that is installed with a seat belt and comes with a tether can use the tether for additional security.

Second-row seats

1. **For outer seats:** Raise the head restraint to its highest position, then route the tether strap through the head restraint legs.

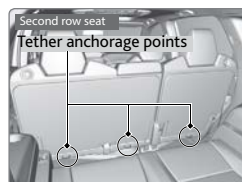

For center seat: Lower the head restraint to its lowest position, then route the tether strap over the top of the head restraint.

2. Make sure the strap is not twisted, and secure the tether strap hook onto the anchor.
3. Tighten the tether strap as instructed by the child seat manufacturer.

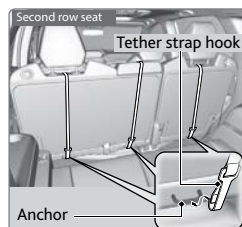

Third-row seats

1. Pull up the head restraint and push rearward until it latches, then route the tether strap through the head restraint legs.
2. Open the anchor cover.
3. Make sure the strap is not twisted, and secure the tether strap hook onto the anchor.
4. Tighten the tether strap as instructed by the child seat manufacturer.

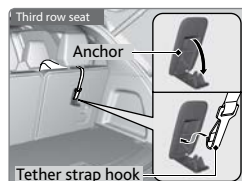
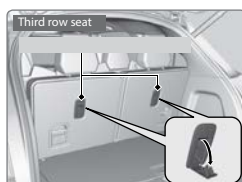

■ Protecting Larger Children

When a child is too big for a child seat, secure the child in a rear seat using the lap/shoulder seat belt.

Have the child sit upright and all the way back, then ensure the following:

- The child's knees bend comfortably over the edge of the seat.
- The shoulder belt crosses between the child's neck and arm.
- The lap part of the seat belt is as low as possible, touching the child's thighs.
- The child can stay seated for the whole trip.



If a lap/shoulder belt cannot be used properly, position the child in a booster seat in a rear seating position. For the child's safety, check that the child meets the booster seat manufacturer's recommendations.

Some U.S. states and Canadian provinces/territories require children to use a booster seat until they reach a given age or weight (e.g., 6 years or 60 lbs). Be sure to check current laws in the state or province/territory where you intend to drive.

⚠️ WARNING

Allowing a child age 12 or under to sit in the front can result in injury or death if the passenger's front airbag inflates.

If a larger child must ride in front, move the vehicle seat as far to the rear as possible, have the child sit up properly and wear the seat belt properly, using a booster seat if needed.

Safety Label Locations

Safety labels are in the locations shown. They warn you of potential hazards that can cause serious injury or death. Read these labels carefully.

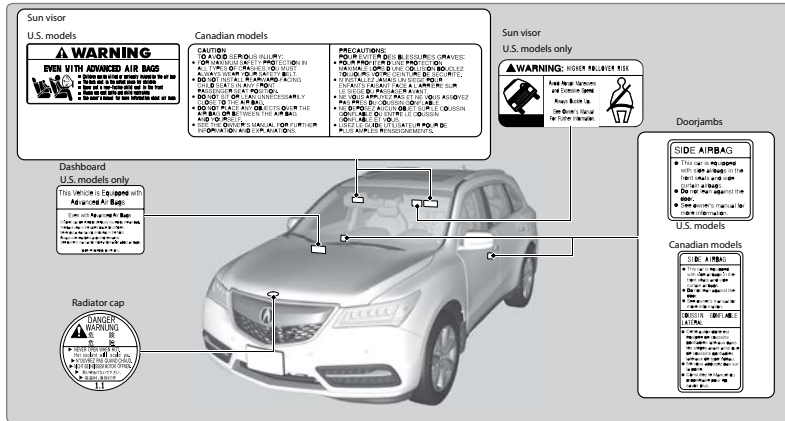

Reporting Safety Defects

In the U.S.

If you believe that your vehicle has a defect which could cause a crash or could cause injury or death, you should immediately inform the National Highway Traffic Safety Administration (NHTSA) in addition to notifying American Honda Motor Co., Inc.

If NHTSA receives similar complaints, it may open an investigation, and if it finds that a safety defect exists in a group of vehicles, it may order a recall and remedy campaign. However, NHTSA cannot become involved in individual problems between you, your dealer, or American Honda Motor Co., Inc.

To contact NHTSA, you may call the Vehicle Safety Hotline toll-free at 1-888-327-4236 (TTY: 1-800-424-9153); go to <http://www.safercar.gov>; or write to: Administrator, NHTSA, 1200 New Jersey Avenue, SE., Washington, DC 20590. You can also obtain other information about motor vehicle safety from <http://www.safercar.gov>.

In Canada

If you believe that your vehicle has a defect which could cause a crash or could cause injury or death, you should immediately inform Honda Canada, Inc., and you may also inform Transport Canada.

If Transport Canada receives similar complaints, it may open an investigation, and if it finds that a safety defect exists in a group of vehicles, it may lead to a recall and remedy campaign. However, Transport Canada cannot become involved in individual problems between you, your dealer, or Honda Canada, Inc.

To contact Transport Canada's Defect Investigations and Recalls Division, you may call 1-800-333-0510. For more information on reporting safety defects or about motor vehicle safety, go to <http://www.tc.gc.ca/roadsafety>.

INSTRUMENT PANEL

Learn about the indicators and displays related to driving the vehicle.

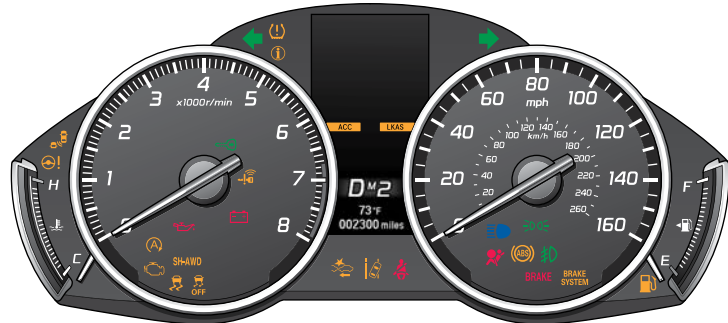

Indicators briefly appear with each engine start and then go out. Red and amber indicators are most critical. Blue and green indicators are used for general information.

Malfunction Indicators

These are the most critical indicators. If they come on and stay lit while driving or at any other time, there may be a problem. See your dealer if necessary.

BRAKE Brake system



- Brake fluid is low.
- There is a malfunction in the brake system.

Press the brake pedal lightly to check pedal pressure. If normal, check the brake fluid level when you stop. If abnormal, take immediate action. If necessary, downshift the transmission to slow the vehicle using engine braking. Have your vehicle repaired immediately.



Low oil pressure

Engine oil pressure is low. Stop in a safe place. Open the hood and check the oil level (see page 134), and add oil if necessary. If the indicator does not turn off, have your vehicle repaired immediately.



Malfunction indicator lamp (check engine light)

- The emissions control system may have a problem, or the fuel cap is loose or missing.
- (Blinks) A misfire in the engine's cylinders is detected. Stop in a safe place, and wait for the engine to cool down.



Charging system

The battery is not charging. Turn off all electrical items, but do not turn off the vehicle to prevent further battery discharge. Have your vehicle repaired immediately.



ABS (Anti-lock Brake System)

There is a problem with the anti-lock brake system. Your vehicle still has normal braking ability, but no anti-lock function.



Supplemental Restraint System (SRS)

There is a problem with one of the airbag systems or seat belt tensioners.



Speed-Sensitive Electric Power Steering (EPS)

There is a problem with the electric power steering system. Stop in a safe place and restart the engine.



Tire Pressure Monitoring System (TPMS)

(Blinks and stays on) There is a problem with the tire pressure monitoring system, or a spare tire* is installed.



Keyless Access system

There is a problem with the keyless access system.



Vehicle Stability Assist (VSA®) system

There is a problem with the VSA system or the hill start assist system.



Brake system

There is a problem with one of the braking systems. Avoid high speeds and sudden braking. Your vehicle still has normal braking ability.



Super-Handling All-Wheel Drive™ (SH-AWD®)*

- There is a problem with the SH-AWD system.
- (Blinks) Stop in a safe place, change the gear to Park, and idle until the indicator goes off.



Blind Spot Information (BSI)*

There is a problem with the BSI system or the sensor is blocked.



Adaptive Cruise Control (ACC) with Low Speed Follow*

There is a problem with the system, or the radar sensor is blocked.



Lane Keeping Assist System (LKAS)*

There is a problem with the system, or the camera is blocked.



Forward Collision Warning (FCW)*

Collision Mitigation Braking System™ (CMBS™)*

There is a problem with the system, the temperature is too high, or the camera is blocked.



Lane Departure Warning (LDW)*

Road Departure Mitigation (RDM)*

There is a problem with the system, the temperature is too high, or the camera is blocked.



Auto idle stop*





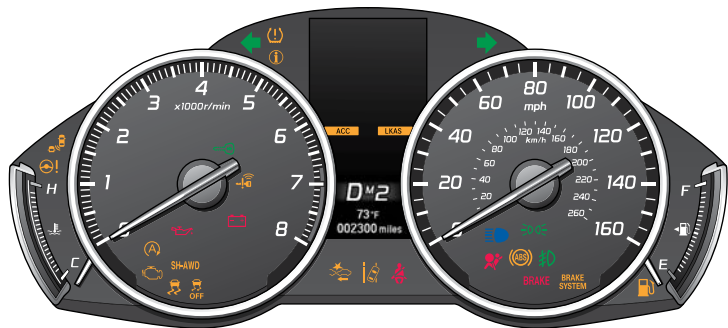

There is a problem with the auto idle stop system.

*if equipped

















Condition Indicators

These indicators may require you to perform an action.

- 
Parking brake
U.S. Canada
 Release the parking brake before driving. You will hear a beep if you drive with it not fully released.
- 
Seat belt reminder
 Make sure seat belts are fastened for you and all passengers. The indicator blinks and beeps sound continuously if you or your front passenger has not fastened your seat belts when you begin driving. If the indicator remains on after seat belts are fastened, see your dealer.
- 
Low fuel
 Refuel as soon as possible. If the indicator blinks, there is a problem with the fuel gauge. See your dealer.
- 
Low tire pressure
 Stop in a safe place, check tire pressures, and inflate tire(s) if necessary.
- 
System message
 When a condition or malfunction indicator comes on, a message also appears on the multi-information display. Check the display for more information.
- 
Immobilizer
 Your remote transmitter cannot be recognized by the vehicle. If the indicator blinks, you may not be able to start the engine. Turn the vehicle off, and then on again. If it continues to blink, there may be a problem with the system. See your dealer.

On/Off Indicators

These indicators remind you when an item is on or off.

-  VSA off
-  VSA engaged (blinks)
-  CRUISE MAIN on
-  CRUISE CONTROL on
-  Turn signals/hazards on
-  High beams on
-  Exterior lights on
-  Fog lights* on
-  FCW*/CMBSTM* off
-  BSI* off
-  ACC* on
-  LKAS* on
-  Auto idle stop* on
-  Auto idle stop* off

*if equipped

Multi-Information Display

Consists of several displays that provide you with useful information.

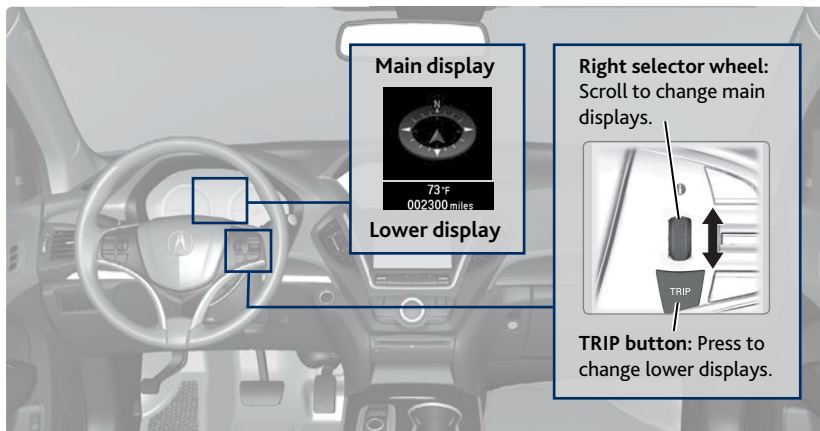

Main Displays

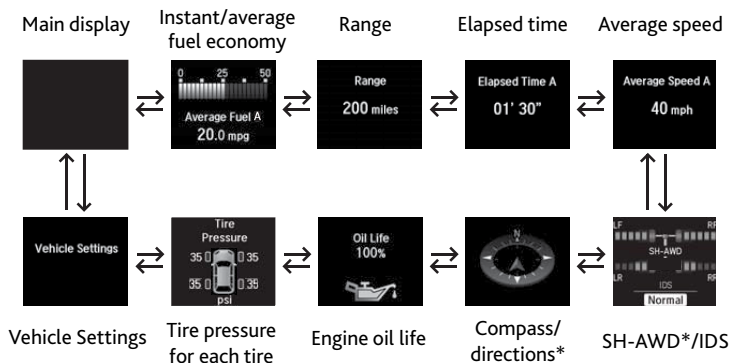

Lower Displays

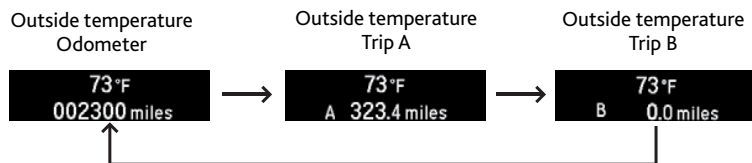

*if equipped

VEHICLE CONTROLS

Learn about the various controls necessary for operating and driving the vehicle.

Using the Remote Transmitter

Lock or unlock the doors and tailgate.

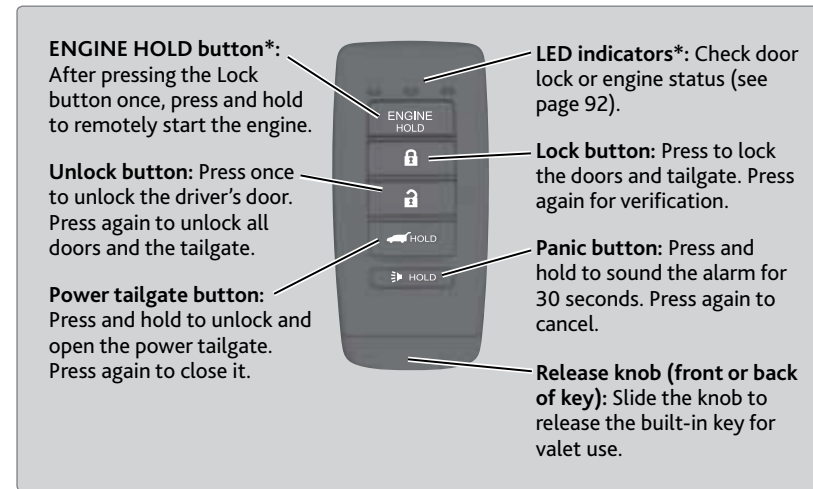

NOTICE

Leaving the remote transmitter in the vehicle can result in theft or accidental movement of the vehicle. Always take it with you whenever you leave the vehicle unattended.

Keyless Access System

When you carry the remote transmitter (for example, in a pocket or purse) and it is outside the vehicle and within range (about 32 inches or 80 cm), you can lock or unlock the doors and tailgate without handling the transmitter.

■ Unlocking/Locking the Doors

To unlock: Grab the driver's door handle when the vehicle is off to unlock the driver's door. Grab the front passenger's (or rear*) door handle to unlock all doors and the tailgate.

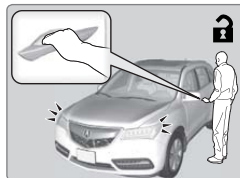

To lock: Press the door lock button on any front (or rear*) door handle when the vehicle is off. If the remote transmitter is inside the vehicle, the doors will not lock.

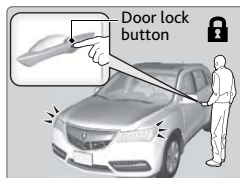

■ Unlocking the Tailgate

Press and hold the tailgate release button under the tailgate handle to unlock and open the tailgate. The vehicle can be on or off.

If there is not enough clearance for the tailgate to fully open, press and hold the tailgate release button until you hear two beeps. The tailgate unlatches, and you can open it manually.

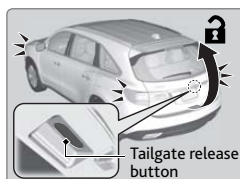

Power Tailgate Operation

Use these methods to operate the power tailgate.

■ Power Tailgate Release Button

The vehicle must be in Park (P).

Press and hold the power tailgate button on the inside of the driver's door to open the tailgate.

Press it again at any time to close it.

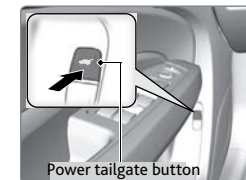

■ Power Tailgate Close Button

Press the power tailgate close button to automatically close the tailgate. Press it again at any time to reverse the tailgate direction.



⚠ WARNING

Closing the power tailgate while anyone is in the path of the tailgate can cause serious injury.

Make sure everyone is clear before closing the tailgate.

**Some models include rear door keyless access.*

Door Operation from Inside the Vehicle

Use these methods to lock or unlock and open or close the doors.

■ Using the Lock Tab

To unlock: Pull the lock tab rearward. When you unlock either front door using the lock tab, the specific door (driver's or passenger's) unlocks.

To lock: Push the lock tab forward. When you lock the door using the lock tab on the driver's door, all the other doors and tailgate lock at the same time.

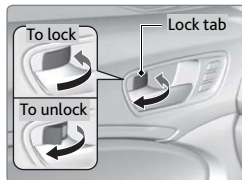

■ Using the Master Door Lock Switch

To unlock: Press the unlock side of the switch to unlock all doors and the tailgate.

To lock: Press the lock side of the switch to lock all doors and the tailgate.

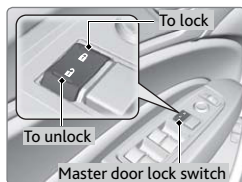

■ Using the Front Door Inner Handle

Pull the front door inner handle. The door unlocks and opens in one motion. Unlocking and opening the driver's door from the inner handle unlocks all other doors.

Do not pull a front door inner handle while the vehicle is moving.

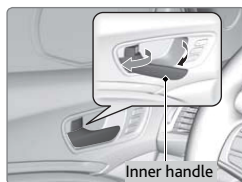

■ Childproof Door Locks

The childproof door locks prevent the rear doors from being opened from the inside regardless of the position of the lock tab.

Slide the lever in the rear door to the lock position, and close the door.

Open the door using the outer door handle.

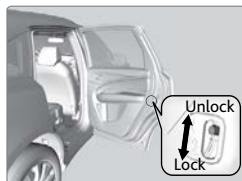

Power Window Operation

The power windows can be opened and closed when the vehicle is on by using the switches on the doors. The switches on the driver's side can be used to open and close all the windows.

■ Automatic Operation

To open: Push the switch down firmly.

To close: Pull the switch up firmly.

The window opens or closes completely. To stop the window at any time, push or pull the switch again briefly.

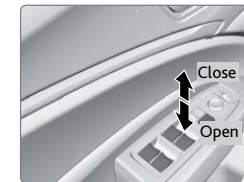

■ Manual Operation

To open: Push the switch down lightly.

To close: Pull the switch up lightly.

Release the switch when the windows reach the desired position.

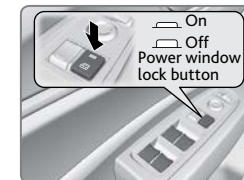

■ Power Window Lock

Push in the power window lock button so only the driver's window can be operated.

⚠ WARNING

Closing a power window on someone's hands or fingers can cause serious injury.

Make sure your passengers are away from the windows before closing them.

Power Moonroof Operation

The moonroof can be opened and closed when the vehicle is on by using the switch on the ceiling.

Automatic Operation

To open: Push the switch back firmly to the second detent, then release.

To close: Push the switch forward firmly to the second detent, then release.

The moonroof opens or closes completely. To stop the moonroof at any time, push the switch briefly.

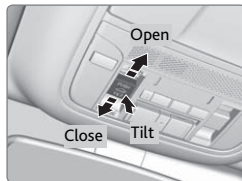

Manual Operation

To open: Push and hold the switch back to the first detent until the desired position is reached.

To close: Push and hold the switch forward to the first detent until the desired position is reached.

Moonroof Tilt

To tilt: Push the center of the switch.

To close: Push the switch forward firmly, then release.

NOTICE

Opening the moonroof in below freezing temperatures or when it is covered with snow or ice can damage the moonroof panel or motor.

WARNING

Closing the moonroof on someone's hands or fingers can cause serious injury.

Make sure your passengers are away from the moonroof before closing it.

Interior and Exterior Lights

Operate interior and exterior lights when the vehicle is on or off.

Exterior Lights

Rotate the switch on the headlight lever to operate the exterior lights. Push the lever forward to turn on the high beams. Return the lever to its original position for low beams.

- OFF All exterior lights are off.
- AUTO Turn on the automatic lighting feature. Headlights turn on or off depending on ambient brightness when the vehicle is on. Headlights automatically come on after the wipers are engaged for a certain time.

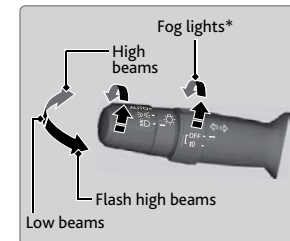

- Turn on exterior lights except headlights.
- Turn on all exterior lights including headlights.
- Turn on fog lights.*

Brightness Control

Adjust instrument panel brightness when the vehicle is on.

To brighten: Press the + button.

To dim: Press the - button.

A beep sounds when the brightness reaches minimum or maximum.



Headlight Washers*

Canadian models

Turn the headlights on. Press the headlight washer button to operate the washers.

The headlight washers also operate when you first turn on the windshield wipers.



*if equipped

TABLE OF CONTENTS

VISUAL INDEX

SAFETY INFORMATION

INSTRUMENT PANEL

VEHICLE CONTROLS

AUDIO AND CONNECTIVITY

BLUETOOTH® HANDSFREELINK®

ACURALINK®

NAVIGATION

DRIVING

HANDLING THE UNEXPECTED

MAINTENANCE

SPECIFICATIONS

CLIENT INFORMATION

VOICE COMMAND INDEX

INDEX

Interior Lights

Change the interior light settings using the switches on the ceiling.

Front lights

On position: Interior lights remain on.

Door-activated position: Interior lights come on when any of the doors are opened, the driver's door is unlocked, or the vehicle is turned off.

Off position: Interior lights remain off.

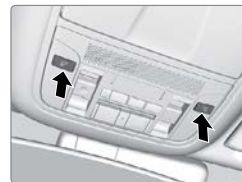
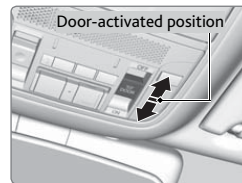

Press the map light button to turn lights on or off.

Cargo lights

Located on the inside of the tailgate door.

On position: The light comes on when the tailgate is open and goes off when it is closed.

Off position: The light stays off.

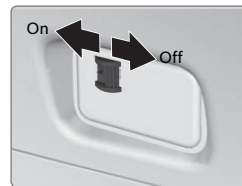

One-Touch Turn Signal

Use this quick and convenient method to signal a lane change.

Lightly push the turn signal lever up or down for a three-blink sequence.

For a continuous signal, push the lever up or down until it locks into place.

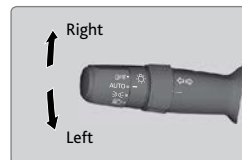

Wiper Operation

The windshield wipers and washers can be used when the vehicle is on. Move the wiper lever up or down to the desired position.

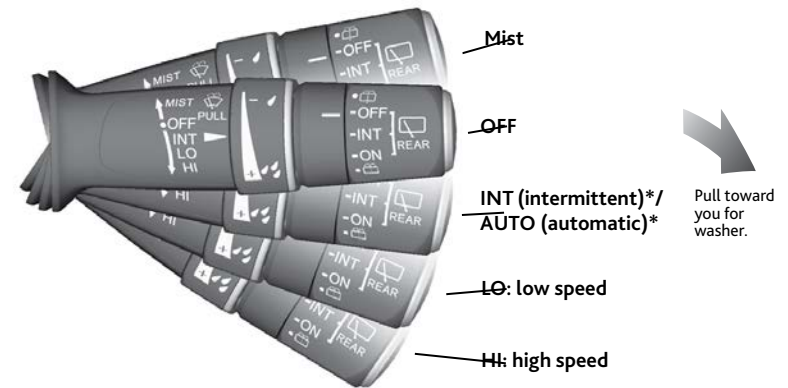

Headlight-Wiper Integration

When the headlights are in the AUTO position, they automatically turn on when the front wipers operate several times within a certain interval. The headlights turn off shortly after the wipers are turned off, or if there is enough ambient light.

Intermittent Wipers*

When you move the lever to the INT position, the wipers operate based on the delay adjustment.

Rotate the adjustment ring to adjust the wiper delay.

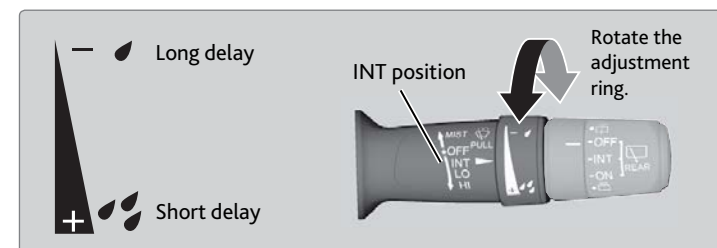

*if equipped

Automatic Rain-Sensing Wipers*

When you move the lever to the AUTO position while driving in rainy weather, the wipers operate based on the amount of detected rainfall.

Put the lever in the AUTO position only when driving in rainy weather.

Rotate the adjustment ring to adjust the rainfall sensor sensitivity.

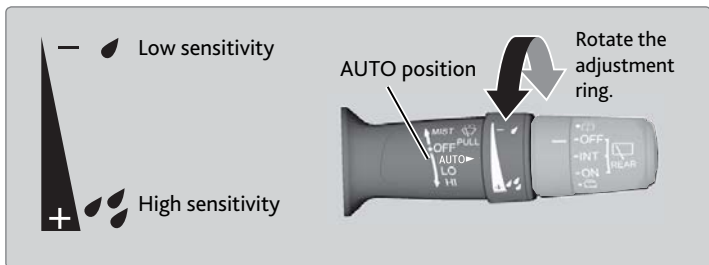

Return the lever to the OFF position when rain stops.

NOTICE

Always ensure the wiper lever is in the OFF position before entering a car wash to prevent severe damage to the windshield wiper system.

Rear Wiper

Rotate the end of the wiper lever to operate the rear wiper.

When you change the gear to Reverse (R) and the front wipers are activated, the rear wiper activates even if the switch is off.



NOTICE

Do not use the wipers when the windshield is dry. The windshield will get scratched, or the rubber blades will get damaged.

In cold weather, the blades may freeze to the windshield, becoming stuck. Operating the wipers in this condition may damage the wipers. Use the defroster to warm the windshield, or manually clear the windshield of ice and snow before turning on the wipers.

Adjusting the Seats

Make seat adjustments before driving to ensure the best comfort and safety.

Adjusting the Front Seats

Adjust the driver's seat as far back as possible while allowing you to maintain full control of the vehicle. You should be able to sit upright and well back in the seat, adequately press the pedals without leaning forward, and grip the steering wheel comfortably. The passenger's seat should be adjusted so that it is as far back from the front airbag in the dashboard as possible.

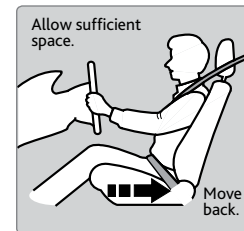

The National Highway Traffic Safety Administration and Transport Canada recommend that drivers allow at least 10 inches (25 cm) between the center of the steering wheel and the chest.

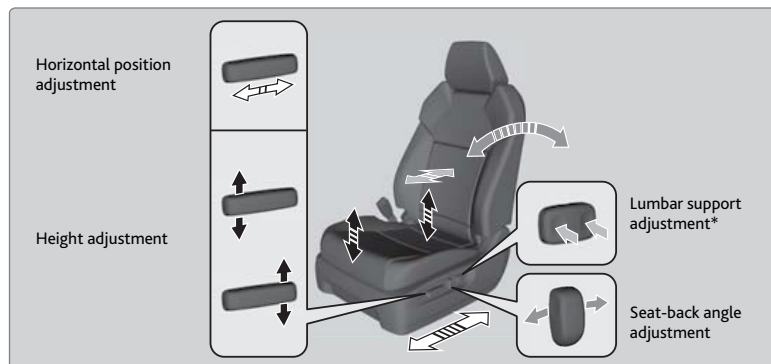

⚠ WARNING

Sitting too close to a front airbag can result in serious injury or death if the front airbags inflate.

Always sit as far back from the front airbags as possible while maintaining control of the vehicle.

⚠ WARNING

Reclining the seat-back too far can result in serious injury or death in a crash. Adjust the seat-back to an upright position, and sit well back in the seat.

*if equipped

TABLE OF CONTENTS

VISUAL INDEX

SAFETY INFORMATION

INSTRUMENT PANEL

VEHICLE CONTROLS

AUDIO AND CONNECTIVITY

BLUETOOTH® HANDSFREELINK®

ACURALINK®

NAVIGATION

DRIVING

HANDLING THE UNEXPECTED

MAINTENANCE

SPECIFICATIONS

CLIENT INFORMATION

VOICE COMMAND INDEX

INDEX

TABLE OF CONTENTS

VISUAL INDEX

SAFETY INFORMATION

INSTRUMENT PANEL

VEHICLE CONTROLS

AUDIO AND CONNECTIVITY

BLUETOOTH® HANDSFREELINK®

ACURALINK®

NAVIGATION

DRIVING

HANDLING THE UNEXPECTED

MAINTENANCE

SPECIFICATIONS

CLIENT INFORMATION

VOICE COMMAND INDEX

INDEX

⚠️WARNING

Sitting improperly or out of position can result in serious injury or death in a crash.
Always sit upright, well back in the seat, with your feet on the floor.

■ Adjusting the Head Restraints

Your vehicle is equipped with head restraints in all seating positions. Head restraints are most effective for protection against whiplash and other rear-impact crash injuries.

The center of the back of the occupant's head should rest against the center of the restraint. The tops of the occupant's ears should be level with the center height of the restraint.

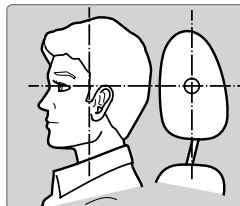

Front and second-row seats

To raise the head restraint: Pull it upward.

To lower the head restraint: Push it down while pressing the release button.

To remove the head restraint: Pull the restraint up as far as it will go. Then push the release button, and pull the restraint up and out.

To reinstall a head restraint: Insert the legs back in place, then adjust the head restraint to an appropriate height while pressing the release button. Pull up on the restraint to make sure it is locked in position.

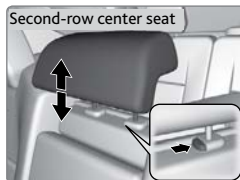
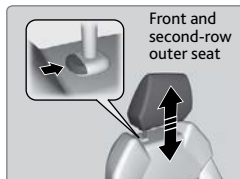

Third-row seats

To fold down the head restraint: Pull the handle.

To fold up the head restraint: Pull up the head restraint and push it back until it latches into place.



For a head restraint system to work properly:

- Do not hang any items on the head restraints or from the restraint legs.
- Do not place any object between an occupant and the seat-back.
- Install each restraint in its proper location.

⚠️WARNING

Improperly positioning head restraints reduces their effectiveness and increases the likelihood of serious injury in a crash.
Make sure head restraints are in place and positioned properly before driving.

⚠️WARNING

Failure to reinstall, or correctly reinstall, the head restraints can result in severe injury during a crash.
Always replace the head restraints before driving.

■ Floor Mats

Position the front and rear seat floor mats properly and anchor them. If they are not properly positioned, the floor mats can interfere with the front seat functions.

Do not put additional floor mats on top of the anchored mats.



Adjusting the Mirrors

Adjust the angle of the mirrors for the best visibility when you are sitting in the correct driving position.

Automatic Dimming Rearview Mirror

When driving after dark, the automatic dimming function reduces the glare from headlights behind you. Power door mirrors also dim.*

The function cancels when the gear is changed to Reverse (R).



Power Door Mirrors

Adjust the power door mirrors when the vehicle is on.

L/R selector switch: Select the left or right mirror. After adjusting the mirror, return the switch to the center position.

Mirror position adjustment switch: Press the switch left, right, up, or down to move the mirror.

Folding door mirror button*: Press to fold the door mirrors in or out.

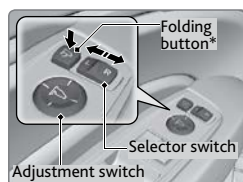

Reverse Tilt Door Mirrors

Either side door mirror can tilt downward when you change the gear to Reverse (R) to improve visibility on the selected side of the vehicle when reversing. The mirror returns to its original position when you change the gear out of Reverse.

When in Reverse, slide the selector switch to the left or right side.

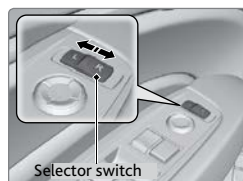

**if equipped*

Adjusting the Steering Wheel

The steering wheel height and distance from your body can be adjusted so that you can comfortably grip the steering wheel in an appropriate driving posture.

Press and hold the adjustment switch to move the steering wheel in, out, up, or down.

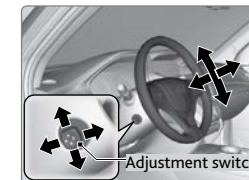

WARNING

Adjusting the steering wheel position while driving may cause you to lose control of the vehicle and be seriously injured in a crash.

Adjust the steering wheel only when the vehicle is stopped.

Driving Position Memory System

You can store two driver's seat, steering wheel, and door mirror positions into memory when the vehicle is on. When you unlock and open the driver's door with a remote transmitter, the items adjust automatically to one of the two preset positions.

1. Adjust the seat, steering wheel, and mirrors to your preferred positions.
2. Press SET.
3. Press and hold memory button 1 or 2. You will hear two beeps when the memory is set. The positions are now linked to the corresponding Driver 1 or Driver 2 remote transmitter.

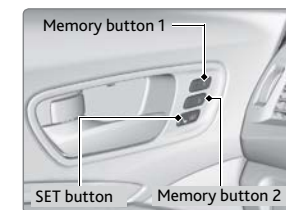

Press one of the memory buttons to recall previously stored positions.

Lumbar positions cannot be stored.

Rear Seats

Adjust second-row seats, access third-row seats, or fold down seats for additional cargo space.

■ Adjusting the Second-Row Seats

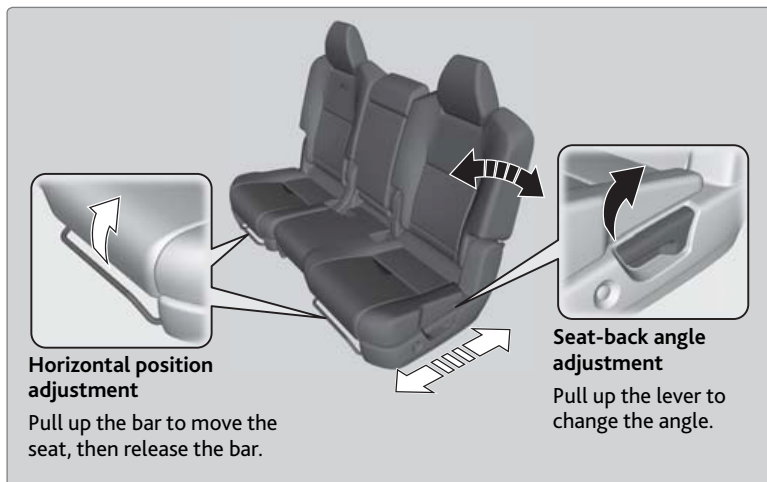

■ Accessing the Third-Row Seats

Press the button on the second-row seat back or outer seat side. The second-row seat slides forward to allow easy access to the third row.

The button is inoperable when the vehicle is moving.

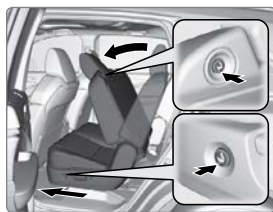

■ Folding Down the Second-Row Seats

Separately fold down the left and right halves of the second-row seat to make room for cargo.

1. Store the center seat belt by inserting the latch plate into the slot on the side of the anchor buckle.
2. Retract the seat belt into the holder on the ceiling.
3. Lower the center head restraint to its lowest position. Put the armrest back into the seat-back.
4. Pull up the seat-back angle adjustment lever.

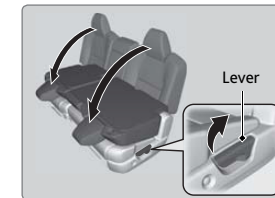

To return the seat to its original position, pull up the seat-back to an upright position until it is securely latched into place. Reposition the seat belts as necessary.

■ Folding Down the Third-Row Seats

Separately fold down the left and right halves of the third-row seat to make room for cargo.

1. Pull the handle on the seat-back. The head restraint folds down.
2. Push the seat-back forward while pulling the handle.



To return the seat to its original position, pull up the seat-back while pulling up the handle. Push the head restraint up to its original position.

HomeLink® Garage Opener

Program your vehicle to operate up to three remote-controlled devices around your home—such as garage doors, lighting, or home security systems—using the buttons on the ceiling.

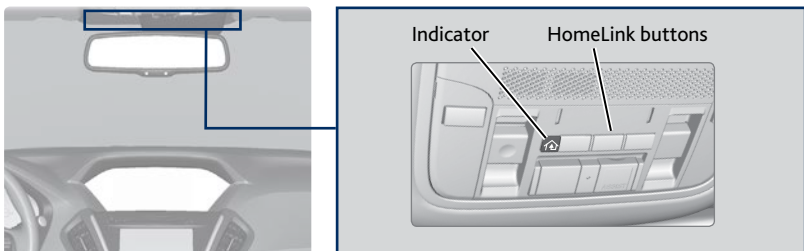

Training a Button

Park near the system you want to program, and follow the instructions in the flowchart below.

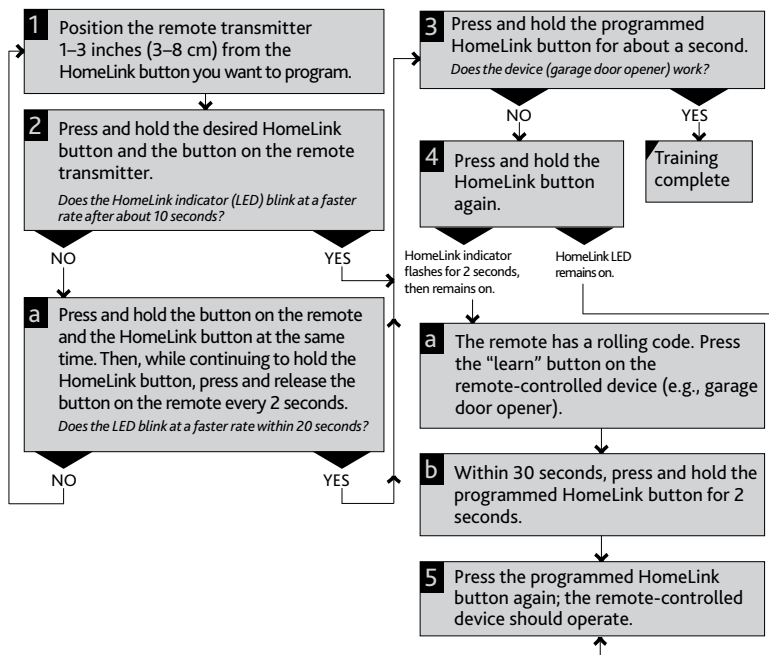

To retrain a button or erase codes, see the Owner's Manual on the Owner Information CD or at owners.acura.com (U.S.) or myacura.ca (Canada). If you need help, call HomeLink at (800) 355-3515 or visit www.homelink.com.

Climate Control System

Set your preferred interior temperature by selecting the proper mix of heated or cooled air and fan speed.

Front Operation

Use the On-Demand Multi-Use Display (ODMD) touchscreen or the buttons below the screen to operate the system.

On-Demand Multi-Use Display (ODMD)

When you select a climate control icon, a new screen appears where you can make adjustments or change settings.

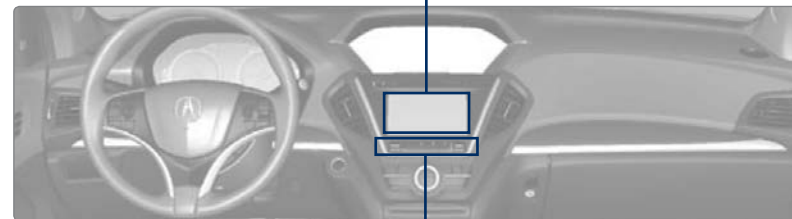

Climate control buttons

TABLE OF CONTENTS

VISUAL INDEX

SAFETY INFORMATION

INSTRUMENT PANEL

VEHICLE CONTROLS

AUDIO AND CONNECTIVITY

BLUETOOTH® HANDSFREELINK®

ACURALINK®

NAVIGATION

DRIVING

HANDLING THE UNEXPECTED

MAINTENANCE

SPECIFICATIONS

CLIENT INFORMATION

VOICE COMMAND INDEX

INDEX

Rear Operation

Use the On-Demand Multi-Use Display (ODMD) touchscreen to operate the system.

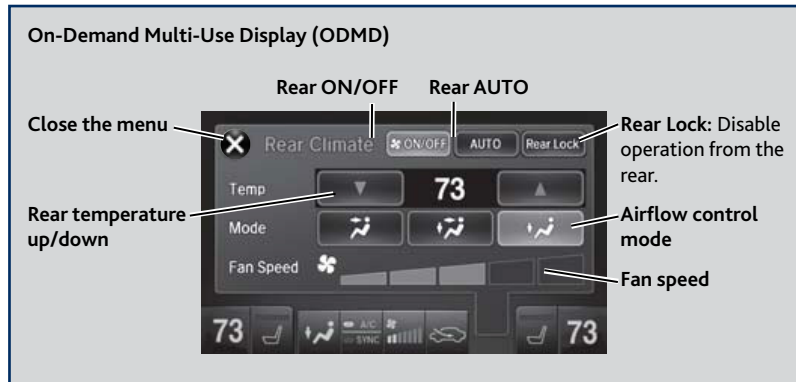

Rear Climate Control Buttons

Use the buttons on the back of the center console to operate the rear system.

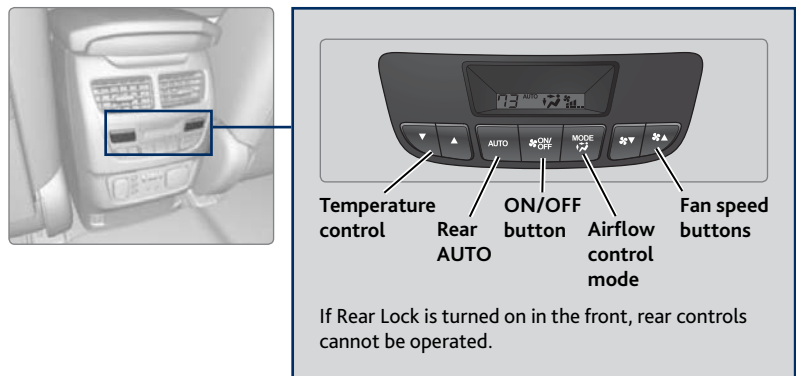

Heated Steering Wheel*

Heat the steering wheel to a comfortable temperature when the vehicle is on.

Press the heated steering wheel button. Press the button again to turn it off.

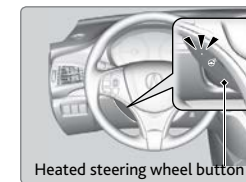

Heated Windshield Button*

Turn the vehicle on. Press the heated windshield button to de-ice the windshield.

The heated windshield may automatically activate when the outside temperature is below 4° C, and deactivate when the temperature reaches 6° C.

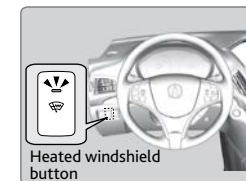

*if equipped (Canadian models)

Seat Heaters and Ventilation*

Quickly warm or ventilate the seats when the vehicle is on.

■ Front Seat Heaters or Ventilation

Use the On-Demand Multi-Use Display (ODMD) touchscreen to operate the front seat heaters or ventilation.

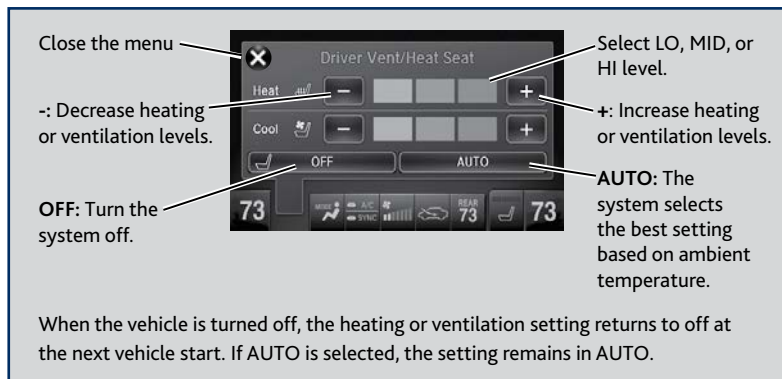

■ Second-Row Outer Seat Heaters*

Press the seat heater button on the back of the center console to cycle through settings: HI, MID, LO, and OFF. Indicators appear for each setting.



⚠ WARNING

Heat-induced burns are possible when using seat heaters.

Persons with a diminished ability to sense temperature (e.g., persons with diabetes, lower-limb nerve damage, or paralysis) or with sensitive skin should not use the seat heaters.

*if equipped

Customized Features

You can easily customize many features of your vehicle. The customized settings are recalled every time you unlock the driver's door with the remote (Driver 1 or Driver 2). Settings are unique to each remote.

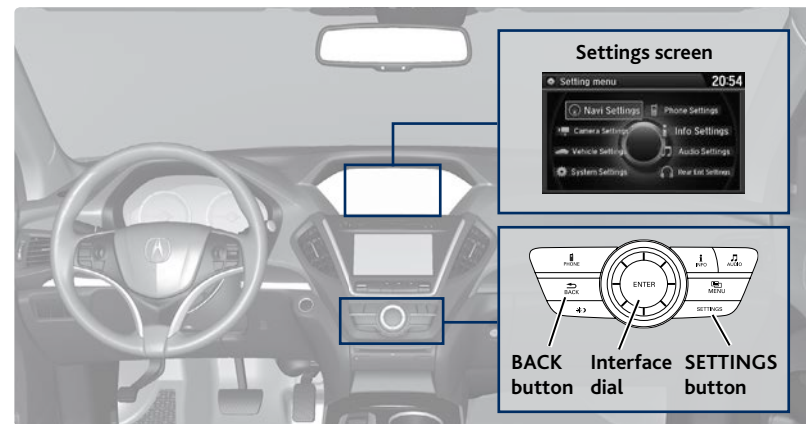

■ How to Change a Setting

The vehicle must be in Park (P) to select Vehicle Settings. Use the interface dial to make and enter selections.

1. Press SETTINGS.
2. Select an option (System, Vehicle, Camera, Audio, Phone, Info, or Navi*).
3. Select a setting option, and make your preferred changes.
4. Press BACK to exit out of the menus.

■ Setting the Clock

On vehicles without navigation, use the interface dial to adjust the time in the clock display. On vehicles with navigation, the time is automatically set using GPS signals.

1. Press SETTINGS.
2. Select System Settings.
3. Select Clock Adjustment.
4. Rotate the interface dial to change the hour value. Press the interface dial to select minutes, and rotate to change the value. Press the interface dial to exit the screen.
5. Press BACK to exit out of the menus.

*if equipped

TABLE OF CONTENTS

VISUAL INDEX

SAFETY INFORMATION

INSTRUMENT PANEL

VEHICLE CONTROLS

AUDIO AND CONNECTIVITY

BLUETOOTH® HANDSFREELINK®

ACURALINK®

NAVIGATION

DRIVING

HANDLING THE UNEXPECTED

MAINTENANCE

SPECIFICATIONS

CLIENT INFORMATION

VOICE COMMAND INDEX

INDEX

AUDIO AND CONNECTIVITY

Learn how to operate the vehicle's audio system.

Basic Audio Operation

Connect audio devices and operate buttons and displays for the audio system.

■ USB Port

Connect a USB flash drive or other audio device, such as an iPod® or iPhone®.

1. Slide back the center console cover. Open the USB port cover.
2. Install the flash drive or iPod cable to the USB port.



iPod and iPhone are trademarks of Apple, Inc.

State or local laws may prohibit the operation of handheld electronic devices while operating a vehicle.

■ Auxiliary Input Jack

Connect standard audio devices with a 1/8-inch (3.5 mm) stereo miniplug.

1. Slide back the center console cover. Open the AUX cover.
2. Connect the device to the input jack.
3. Use the device to control the audio.



■ AC Power Outlet*

Located on the back of the center console. Power is supplied when the vehicle is on for devices up to 115 volts rated 150 watts or less.

1. Open the cover.
2. Plug in the device slightly, turn it 90° clockwise, then push it in all the way.

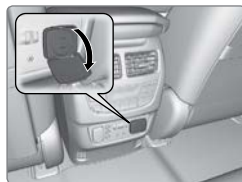

NOTICE

Do not use the AC power outlet for electric appliances that require high initial peak wattage, such as cathode-ray tube type televisions, refrigerators, electric pumps, etc. It is not suitable for devices that process precise data, such as medical equipment, and that require an extremely stable power supply, such as microcomputer-controlled electric blankets, touch sensor lamps, etc.

*if equipped

■ Accessory Power Socket

Located in the center console, front pocket, and rear cargo area. Open the socket cover to use power when the vehicle is on.



NOTICE

Do not insert an automotive type cigarette lighter element. This can overheat the power socket.

■ Steering Wheel Controls

Operate certain functions of the audio system using the steering wheel controls.

Left selector wheel: Roll up or down to adjust volume. Press to mute. Move (or hold) left or right to change stations or tracks.

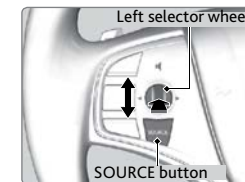

SOURCE button: Cycle through available audio modes.

FM/AM/SiriusXM® Radio

Move right or left for the next or previous station. Move and hold right or left for the next or previous strong station.

CD/HDD*/iPod*/USB/Bluetooth® Audio

Move right for the next or previous track. Move and hold right or left for the next or previous folder (CD/USB).

Pandora®/Aha™

Move right for the next song. Move and hold right or left for the next or previous station.

■ Adjusting the Sound

Adjust various sound settings. Use the interface dial to make and enter selections.

1. Press SETTINGS.
2. Select Audio Settings.
3. Select Sound.
4. Select the sound setting to adjust.
5. Adjust the setting to the desired level.
6. Press BACK to exit the menu.



On-Demand Multi-Use Display (ODMD)

Operate the audio system using either the touchscreen or buttons.

The functions shown here can be used with most audio sources. Refer to subsequent audio pages for more specific functions. Options that appear depend on the selected audio source.

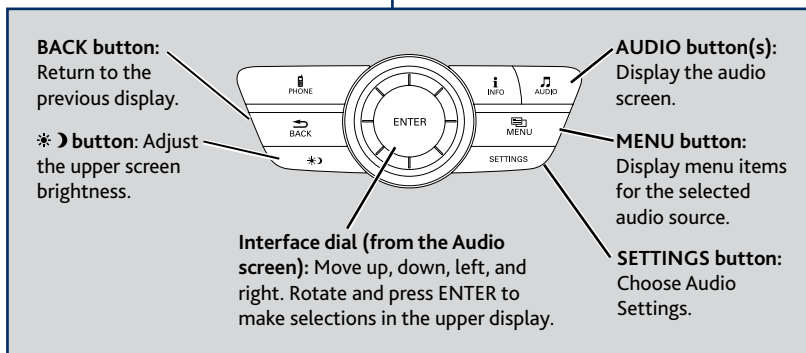
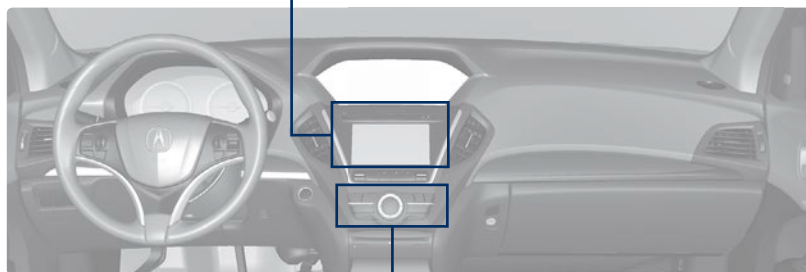
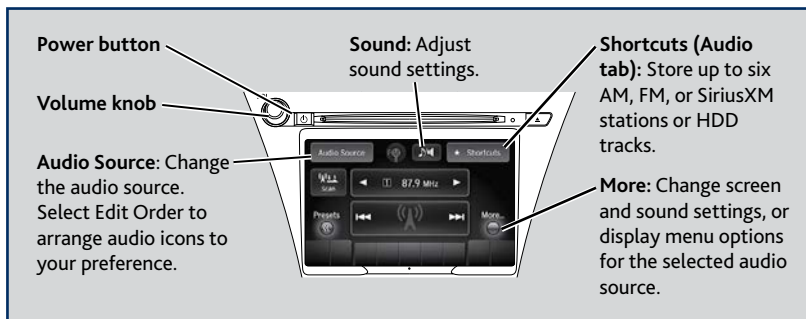

FM/AM Radio

Play FM or AM radio stations.

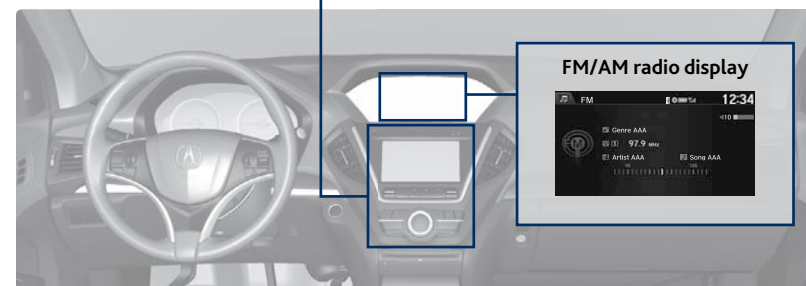
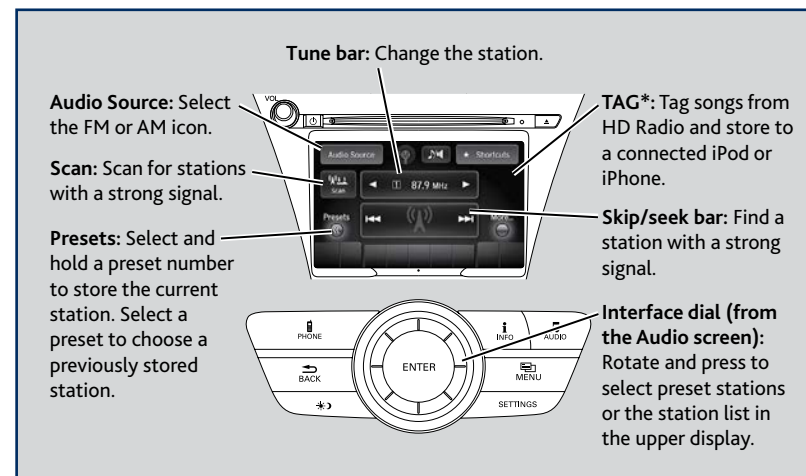

TABLE OF CONTENTS

VISUAL INDEX

SAFETY INFORMATION

INSTRUMENT PANEL

VEHICLE CONTROLS

AUDIO AND CONNECTIVITY

BLUETOOTH® HANDSFREELINK®

ACURALINK®

NAVIGATION

DRIVING

HANDLING THE UNEXPECTED

MAINTENANCE

SPECIFICATIONS

CLIENT INFORMATION

VOICE COMMAND INDEX

INDEX

SiriusXM® Radio

Available on a subscription basis only. For more information or to subscribe, contact your dealer, or visit www.siriusxm.com (U.S.) or www.siriusxm.ca (Canada).

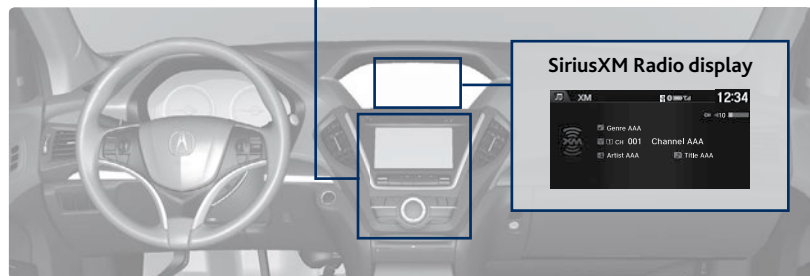
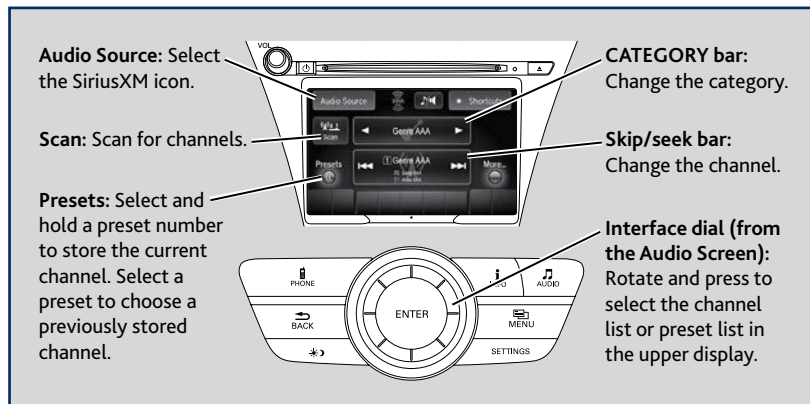

Available in the U.S. and Canada, except Hawaii, Alaska, and Puerto Rico. XM® is a registered trademark of Sirius XM Radio, Inc.

Compact Disc (CD) or USB Flash Drive

For CDs: The audio system supports audio CDs, CD-Rs, and CD-RWs in MP3, WMA, or AAC formats.

For USB: Connect your device to the USB port (see page 52).

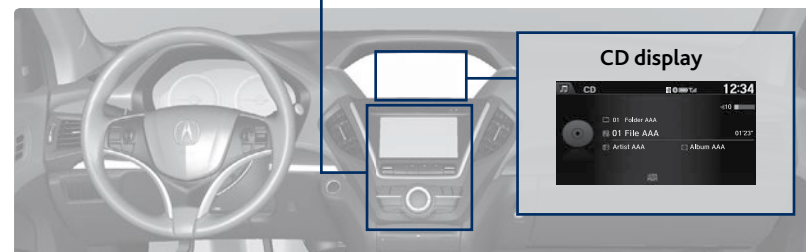
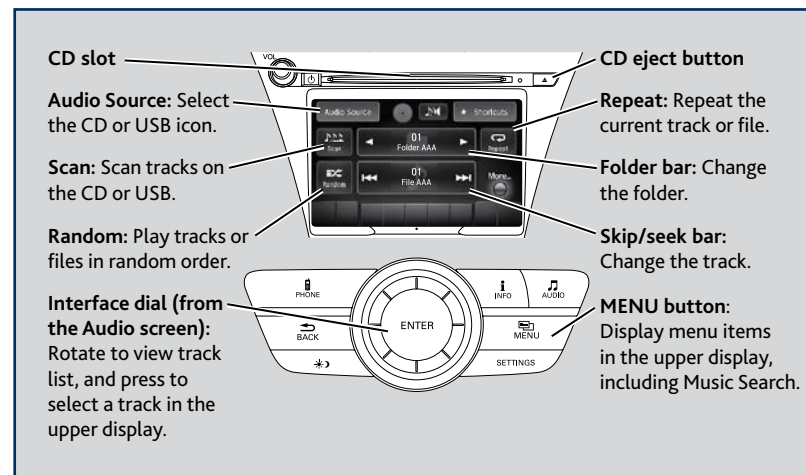

■ Searching for Music

Search for tracks stored on the CD or USB. Use the interface dial to make and enter selections.

1. From the audio screen, press MENU.
2. Select Music Search.
3. Select a search type (artist, album, track, etc.) or folder.
4. Select the song you want to play.



NOTICE

Do not use CDs with adhesive labels or insert a damaged CD. Inserting these types of CDs may cause them to get stuck or damage the audio unit.

Hard Disc Drive (HDD) Audio*

When music CDs are inserted, they are automatically recorded by system default onto the built-in HDD for later playback.

Audio Source: Select the HDD icon.

Scan: Scan all tracks or the first track on each album.

Random: Play the artist, album, or tracks in random order.

Interface dial (from the Audio screen): Rotate to view track list, and press to select a track in the upper display.

Album bar: Change the album.

Repeat: Repeat the artist, album, or track.

Skip/seek bar: Change the track.

MENU button: Display menu items in the upper display, including Music Search.

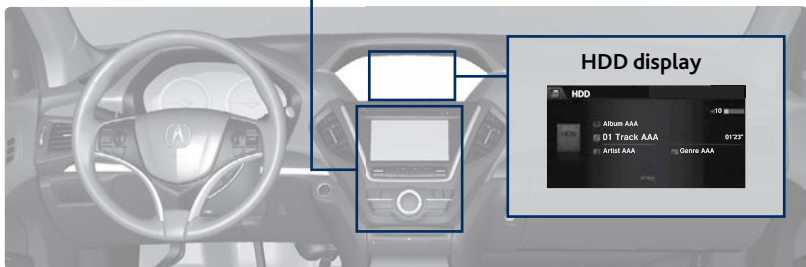

■ Searching for Music

Search for tracks stored on the HDD. Use the interface dial to make and enter selections.

1. From the audio screen, press MENU.
2. Select Music Search.
3. Select a search type (artist, album, track, etc.).
4. Select the song you want to play.



You can also search for and play HDD music using Song By Voice™ (see page 152).

*if equipped

iPod®

Connect your device to the USB port (see page 52).

Audio Source: Select the iPod icon.

Play/pause

Shuffle: Play tracks or albums in random order.

Interface dial (from the Audio screen): Rotate to view tracks, and press to select a track in the upper display.

Album bar: Change the album.

Repeat: Repeat the current track.

Skip/seek bar: Change the track.

MENU button: Display menu items in the upper display, including Music Search.



■ Searching for Music

Search for tracks on the iPod. Use the interface dial to make and enter selections.

1. From the audio screen, press MENU.
2. Select Music Search.
3. Select a search type (artist, album, track, etc.) or folder.
4. Select the song you want to play.

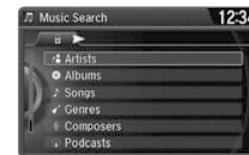

On vehicles with navigation, you can also search for and play iPod music using Song By Voice™ (see page 152).

iPod is a trademark of Apple, Inc.

TABLE OF CONTENTS

VISUAL INDEX

SAFETY INFORMATION

INSTRUMENT PANEL

VEHICLE CONTROLS

AUDIO AND CONNECTIVITY

BLUETOOTH® HANDSFREELINK®

ACURALINK®

NAVIGATION

DRIVING

HANDLING THE UNEXPECTED

MAINTENANCE

SPECIFICATIONS

CLIENT INFORMATION

VOICE COMMAND INDEX

INDEX

Bluetooth® Audio

Play streaming or stored audio from your compatible phone when it is paired to *Bluetooth® HandsFreeLink®* (see page 69). Visit www.acura.com/handsfreelink (U.S.) or www.handsfreelink.ca (Canada) to check phone compatibility. Standard data rates may apply with your phone provider.

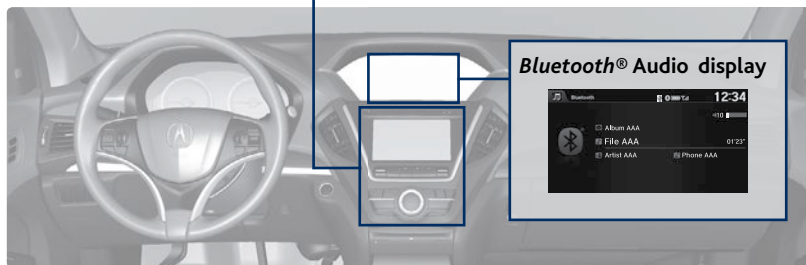
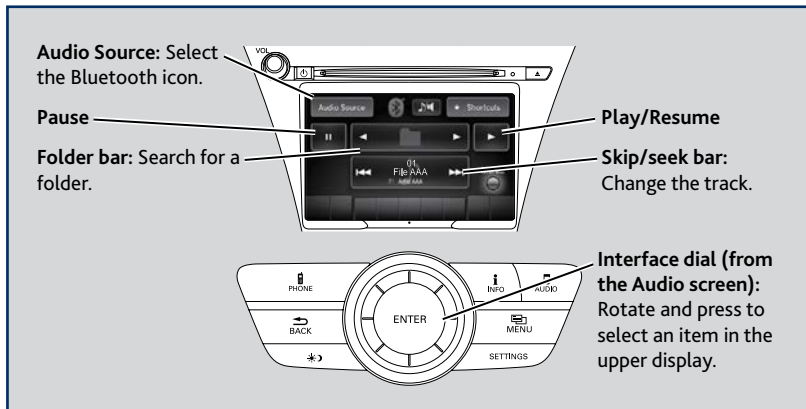

Notes:

- Make sure the volume on your phone is properly adjusted.
- You may need to enable additional settings on your phone for playback.
- The resume/pause function and remote audio controls are not supported on all phones.

State or local laws may prohibit the operation of handheld electronic devices while operating a vehicle. Only launch streaming audio on your phone when safe to do so.

Pandora®

Play and operate Pandora from your phone through the vehicle's audio system. Visit www.acura.com/handsfreelink to check phone compatibility. Standard data rates apply with your phone provider. **Available in the U.S. only.**

Connect your phone when the vehicle is stopped.

For iPhone:

- Connect via *Bluetooth® HandsFreeLink®* (see page 69) or USB (see page 52).
- A pop-up may appear on your phone requesting you to allow access for Pandora to be launched.
- If you cannot operate Pandora through the audio system, it may be streaming through *Bluetooth® Audio*. Make sure Pandora mode on the audio system is selected.
- If Pandora still does not operate, try rebooting the phone and reconnecting the cable if necessary.

For Android and BlackBerry:

- Connect via *Bluetooth® HandsFreeLink®* (see page 69).

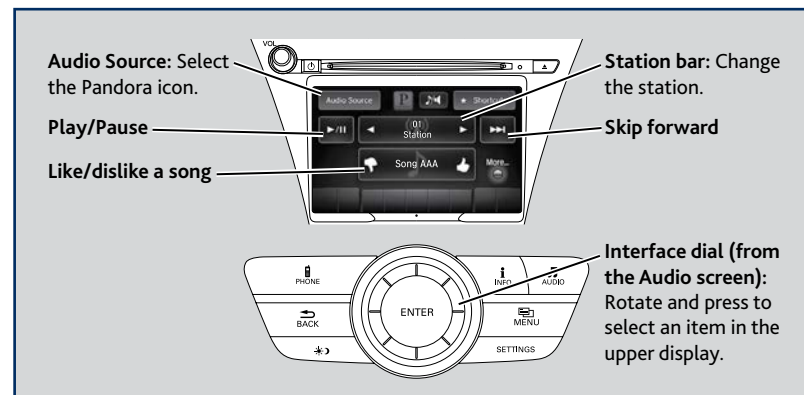

State or local laws may prohibit the operation of handheld electronic devices while operating a vehicle. Only launch streaming audio on your phone when safe to do so.

TABLE OF CONTENTS

VISUAL INDEX

SAFETY INFORMATION

INSTRUMENT PANEL

VEHICLE CONTROLS

AUDIO AND CONNECTIVITY

BLUETOOTH® HANDSFREELINK®

ACURALINK®

NAVIGATION

DRIVING

HANDLING THE UNEXPECTED

MAINTENANCE

SPECIFICATIONS

CLIENT INFORMATION

VOICE COMMAND INDEX

INDEX

AcuraLink featuring Aha™

Access music and information programming, location-based services, and social media through your vehicle's audio system. Visit www.acura.com/handsfreelink (U.S.) or www.handsfreelink.ca (Canada) to check phone compatibility. Standard data rates apply with your phone provider.

Visit owners.acura.com (U.S.) or myacura.ca (Canada) and download the AcuraLink app to your phone prior to using this feature. Make sure you have an active Aha account. Connect your phone when the vehicle is stopped.

For iPhone:

- Connect via **Bluetooth® HandsFreeLink®** (see page 69) or **USB** (see page 52).
- A pop-up may appear on your phone requesting you to allow access for Aha to be launched.
- If you cannot operate Aha through the audio system, it may be streaming through **Bluetooth® Audio**. Make sure Aha mode on your audio system is selected.
- If Aha still does not operate, try rebooting the phone and reconnecting the cable if necessary.

For Android and BlackBerry:

- Connect via **Bluetooth® HandsFreeLink®** (see page 69).

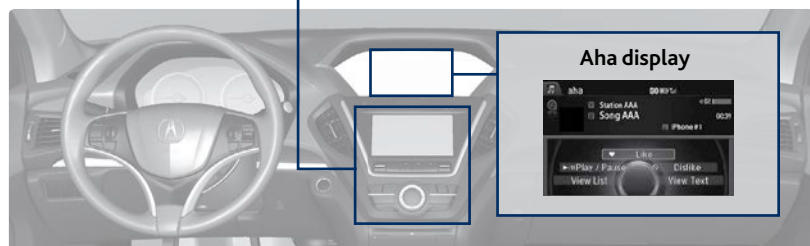
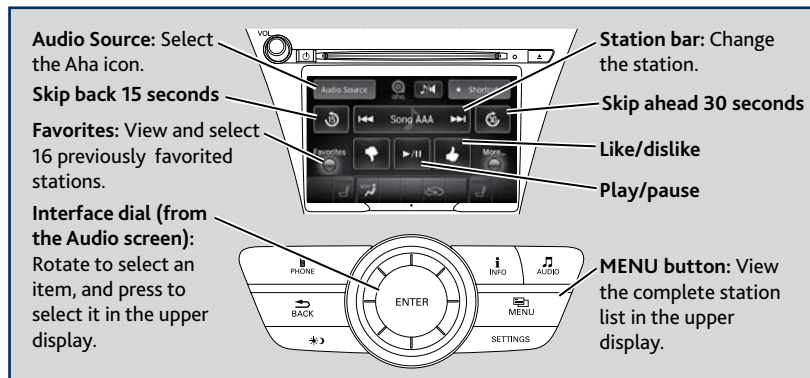

State or local laws may prohibit the operation of handheld electronic devices while operating a vehicle. Only launch streaming audio on your phone when safe to do so.

Rear Entertainment System (RES)*

Rear passengers can enjoy a different audio or entertainment source than front passengers.

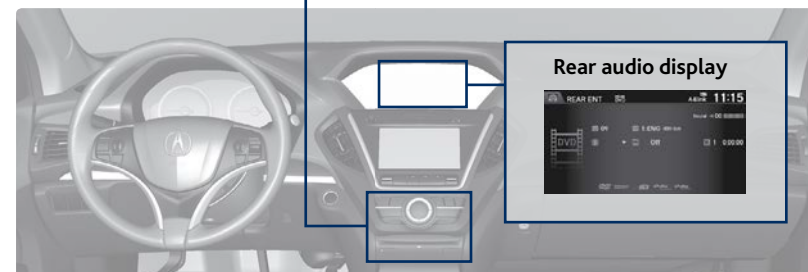
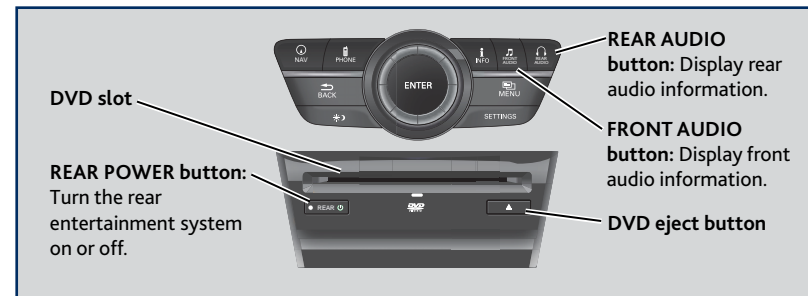

■ Operating the System from the Front

You can operate the rear entertainment system using the front audio controls.

1. Press **REAR POWER** to turn the system on.
2. Press **REAR AUDIO**.
3. Use the front audio controls to choose a media source for the rear system.
4. Press **FRONT AUDIO** to return to the front audio source.

■ Playing a DVD

Insert a DVD into the DVD slot. It begins playing automatically. Use the front or rear controls to navigate the DVD.

NOTICE

This vehicle's overhead mounted display includes mercury-containing components. Upon removal, please reuse, recycle, or dispose of as hazardous waste.

**if equipped*

■ System Components

Retrieve the wireless headphones and open the overhead screen to use the system.

Overhead screen

9-inch RES*: Pull down the bottom edge of the screen, and extend it until it locks into place.

Ultrawide RES*: Press OPEN. Extend the screen until it locks into place.

Fold the screen back into the ceiling when not in use.

Press the release button to detach the rear remote control panel, if desired.



Auxiliary/HDMI* inputs

Auxiliary inputs can be used for video game systems and other devices. Wired headphones can also be used.

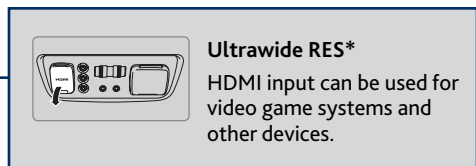
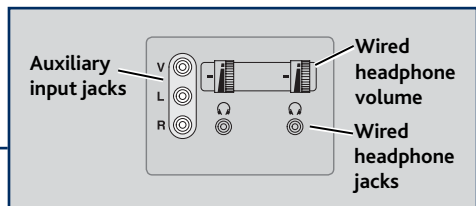

Wireless headphones

Your vehicle comes with two sets of wireless headphones.

Pivot the left earpiece to turn on the headphones.

Turn the dial at the bottom of the right earpiece to adjust the volume.

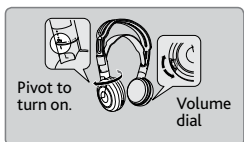

*if equipped

■ Remote Control and Rear Operation

You can operate the system using the rear remote control panel.

DVD/AUX button: Play a DVD, USB, iPod, or auxiliary source.

CD/HDD button: Play a CD or HDD.

XM button: Play XM Radio.

FM/AM button: Play FM or AM radio.

CH/FOLDER button: Change channels, stations, or folders.

Power button: Turn the system on or off.

Light button: Illuminate the remote buttons.

TUNE/SKIP button: Change DVD chapters, audio stations, or tracks.

Play/Pause button (CD/DVD): Play/Pause button (CD/DVD)

TITLE/SCROLL button: Display DVD status or CD titles.

MENU button: Display menu options.

Arrow/ENTER button: Highlight and select items.

SETUP button: Display setup options.

CANCEL button: Go back to the previous display.

1. Make sure REAR POWER is turned on in the front audio controls.
2. From the rear control panel, press the desired audio source button (or the SOURCE button for Ultrawide RES).
3. Press the arrow/ENTER buttons to highlight options on the screen and select them. Use the other rear control panel buttons to operate the system.

TABLE OF CONTENTS

VISUAL INDEX

SAFETY INFORMATION

INSTRUMENT PANEL

VEHICLE CONTROLS

AUDIO AND CONNECTIVITY

BLUETOOTH® HANDSFREELINK®

ACURALINK®

NAVIGATION

DRIVING

HANDLING THE UNEXPECTED

MAINTENANCE

SPECIFICATIONS

CLIENT INFORMATION

VOICE COMMAND INDEX

INDEX

■ **Ultrawide Dual Screen Operation***

Play two different sources side by side on the ultrawide screen. One side of the screen can play a source from the front audio system (FM, DVD, etc.). The other side of the screen can play a connected device, such as a video game system.

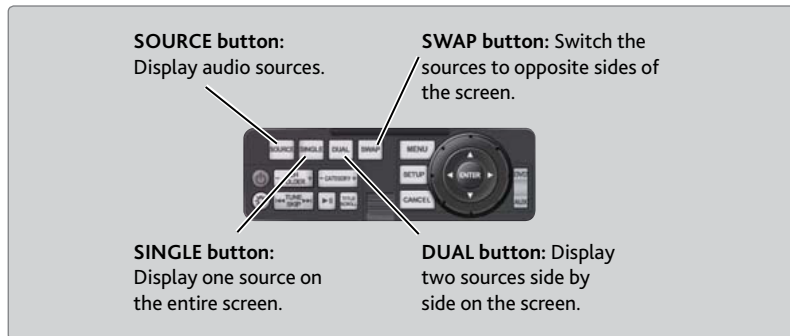

1. Connect a second source through the rear auxiliary jacks or HDMI input (see page 64).
2. From the rear control panel, press DUAL.
3. Select which side the second source plays on.
4. Press SOURCE to select AUX-VIDEO or AUX-HDMI.

*if equipped

BLUETOOTH® HANDSFREELINK®

Learn how to operate the vehicle's hands-free calling system.

Basic HFL Operation

Make and receive phone calls using the vehicle's audio system, without handling your phone. Visit www.acura.com/handsfreelink (U.S.) or www.handsfreelink.ca (Canada) to check phone compatibility.

To reduce the potential for driver distraction, certain manual functions may be inoperable or grayed out while the vehicle is moving. Voice commands are always available.

■ HFL Displays and Controls

Use the controls to enter information and make selections.

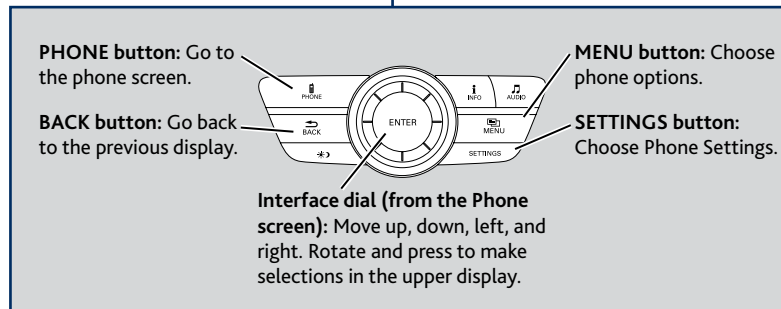
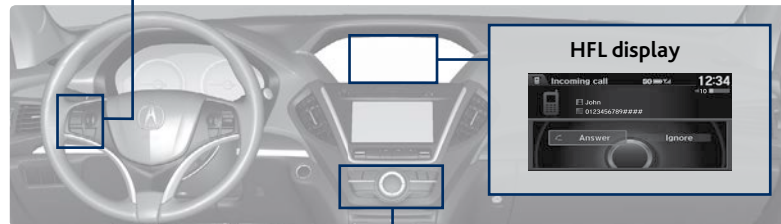
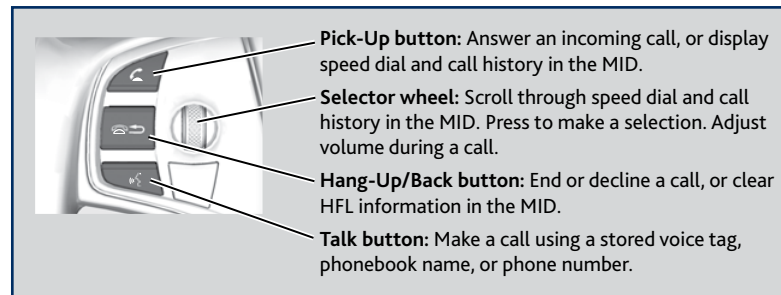

TABLE OF CONTENTS

VISUAL INDEX

SAFETY INFORMATION

INSTRUMENT PANEL

VEHICLE CONTROLS

AUDIO AND CONNECTIVITY

BLUETOOTH® HANDSFREELINK®

ACURALINK®

NAVIGATION

DRIVING

HANDLING THE UNEXPECTED

MAINTENANCE

SPECIFICATIONS

CLIENT INFORMATION

VOICE COMMAND INDEX

INDEX

On-Demand Multi-Use Display (ODMD) screens



When there is an incoming call, select the green Pick-Up or red Hang-Up icon.



When a number keypad is displayed, select numbers to enter.



When an alphabet keyboard is displayed, select letters to enter.

■ Talk Button Tips

On vehicles with navigation, you can say voice commands to operate system functions. For a list of available voice commands, see page 151. Below are some helpful tips:

- When using the Talk button, wait for the beep before saying a command.
- To bypass the system prompts, simply press the Talk button again to say your command.
- Speak in a clear, natural voice.
- Reduce all background noise.
- Adjust the dashboard vents away from the microphone in the ceiling.
- Close the windows and moonroof.

Pairing a Phone

To use hands-free phone and streaming audio functions, you must first pair your phone to the system. This can only be done when the vehicle is stopped. Use the interface dial to make and enter selections.

1. Press SETTINGS.
2. Select Phone Settings.
3. Select Bluetooth Device List (if no phone has been paired) or Connect Phone (if pairing an additional phone).
4. Select Add Bluetooth Device.
5. Make sure your phone is in discovery mode.
6. HFL searches for your phone. Select your phone when it appears on the list.
If your phone does not appear: Select Phone Not Found and search for HandsFreeLink from your phone.
7. HFL gives you a six-digit code. Compare it to the code that appears on your phone. Connect to HFL from your phone.
8. The system asks if you want to enable Phone Synchronization. Select On.



State or local laws may prohibit the operation of handheld electronic devices while operating a vehicle.

Making a Call

You can make calls using several methods.

■ Dialing a Number

Enter a 10-digit phone number to call.

Using voice commands

1. Press the Talk button.
2. Say "Dial" and the phone number. For example, "3-1-0-5-5-5-1-2-3-4."
3. The system begins to dial.



Using the menu

Use the interface dial to make and enter selections. This method is inoperable when the vehicle is moving.

1. Press PHONE.
2. Press MENU.
3. Select Dial.
4. From the navigation screen or the ODMD, enter the phone number. Select the green phone icon to call.



Using the ODMD

Select items on the screen by touching them. This method is inoperable when the vehicle is moving.

1. Select Shortcuts.
2. Select Phone.
3. Select Dial.
4. Enter the phone number and select the green phone icon to call.



■ Using the Phonebook

When your phone is paired, its entire phonebook can be automatically imported to the system. Phone Synchronization must be turned on during the pairing process.

Using voice commands

1. Press the Talk button.
2. Say "Call" and the contact name. For example, "Call John Smith."



Using the menu

Use the interface dial to make and enter selections.

1. Press PHONE.
2. Press MENU.
3. Select Phonebook.
4. Scroll through the list to find the name and number you want to call, and select it to call.



■ Storing Speed Dial Entries

Store up to 20 numbers for quick dialing. Use the interface dial to make and enter selections.

1. Press PHONE.
2. Press MENU.
3. Select Speed Dial, then select New Entry.
4. Select an entry method.
5. If desired, you can create a voice tag for the number. Follow the prompts.



When a voice tag is created, you can press the Talk button and say "Call" and the stored voice tag to quickly call the number.



When speed dial entries are stored, you can add them to the Shortcuts (Phone tab) in the ODMD for quick access.

■ Using Speed Dial and Call History

Make calls quickly using stored speed dial entries or call history numbers.

Using voice commands

1. Press the Talk button.
2. Say "Call" and the stored voice tag name. For example, "Call John Smith."
3. The system begins to dial.



Using the MID

1. Press the Pick-Up button.
2. The speed dial list appears in the MID.
For Call History, move the left selector wheel to the right.
3. Use the left selector wheel to scroll through the list to find the entry you want to call, and select it to call.

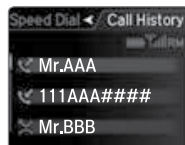

Using the Phone screen

Use the interface dial to make and enter selections.

1. Press PHONE.
2. For Speed Dial, use the interface dial to scroll through the list to find the entry you want to call, and select it to call.
For Call History, move the interface dial to the right and scroll through the list.



Using the ODM D

Select items on the screen by touching them.

1. Select Shortcuts.
2. Select Phone.
3. Select Speed Dial or Call History.
4. Select the desired entry to call.



SMS Text Messaging and E-Mail

Receive and send text messages and e-mails from your paired and linked phone. Visit www.acura.com/handsfreelink (U.S.) or www.handsfreelink.ca (Canada) to check phone compatibility. Standard message rates apply. This feature is limited while the vehicle is moving.

■ Selecting an Account

If your phone has both text message and mail accounts, you can select only one of them at a time to be active and receive notifications.

1. Press SETTINGS.
2. Select Phone Settings.
3. Select Select Account.
4. Select Text Messages or an e-mail account.

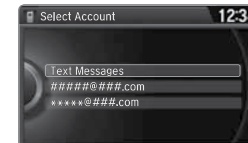

■ Receiving and Responding to Messages

When you receive a new message, a pop-up appears on the display. Use the interface dial to view the message when the vehicle is stopped. You can also reply to it using fixed phrases or call the sender.

1. When the prompt appears, select Read.
2. The message is displayed, and the system reads it aloud.

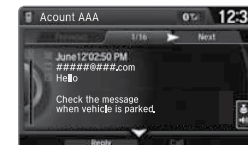

To reply: Select Reply, and choose one of the six available responses. Select Send to send the message. You cannot create a new text message.

To call the sender: Select Call.

Siri™ Eyes Free

Activate Siri through your vehicle when an iPhone® is paired to the system. Visit www.acura.com/handsfreelink (U.S.) or www.acura.ca/siri (Canada) to check phone compatibility.

Back button: Exit Siri Eyes Free mode, or cancel a command.

Talk button: Press and hold to activate Siri Eyes Free mode. The Smartphone screen appears. Say your command after you hear the Siri tone. If you only press and release the Talk button, the standard voice recognition system is activated.



Here are some examples of Siri commands:

"Call John Smith"	"Remind me to pick up dinner"
"Read my new text message"	"Set up a meeting today at 3 p.m."
"Find a nearby sushi restaurant"	"Play song XYZ"

Notes:

- Any requests that include visual feedback from Siri on your phone are not displayed in the vehicle.
- Certain commands rely on the iPhone's features and existing apps.
- To hear turn-by-turn directions or songs through the vehicle, set the audio source to *Bluetooth®* Audio.

Siri and iPhone are trademarks of Apple, Inc.

ACURALINK®*

Learn about Acura's advanced connectivity services.

AcuraLink Messages

Receive messages on vehicle features, safety and emissions recall campaigns, maintenance reminders, and diagnostic information.

Some message features require a phone connection. Visit www.acura.com/handsfreelink (U.S.) or www.handsfreelink.ca (Canada) to check phone compatibility.

■ Viewing Messages

When you receive a new message, an envelope icon appears at the top of the upper display. Use the interface dial to make and enter selections.

1. Press INFO.
2. Select AcuraLink Messages.
3. Select the message category (Feature Guide, Quick Tips, Diagnostic Info, Maintenance Minder, or Recalls/Campaigns).
4. Select the message you want to hear it read aloud.

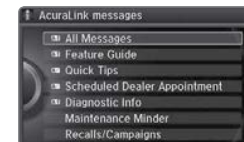

■ Message Options

When you receive certain messages, you can call your dealer if your phone is paired to the system, find the nearest dealer, or schedule service appointments. A current AcuraLink subscription is required to set up this feature and modify your message preferences.



*if equipped

Subscription Features

In addition to standard service, receive benefits such as collision notification, emergency assistance, online security, enhanced navigation searches, and important messages about your vehicle. Requires enrollment and privacy agreement. To subscribe or get more information, visit owners.acura.com (U.S.) or myacura.ca (Canada) or contact a dealer.

■ Emergency Assistance

If your vehicle's airbags deploy or if the unit detects that the vehicle is severely impacted, your vehicle automatically attempts to connect to the AcuraLink operator if your phone is paired to the system and there is sufficient cellular coverage.

If you need to manually connect to the operator, open the cover on the ceiling console and press ASSIST when the vehicle is on.

Once connected, information about your vehicle, its positioning, and its condition will be sent to the operator; you can also speak to the operator when connected.

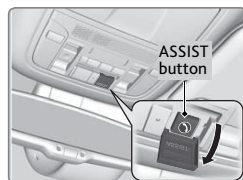

■ Security Features

To use security features, you need your user ID and personal identification number (PIN). Some of these features are also available with the AcuraLink smartphone app. Visit owners.acura.com/apps (U.S.) or myacura.ca (Canada) to download.

- *Stolen vehicle tracking*: Searches and tracks down your vehicle position.
- *Remote door lock/unlock*: Remotely lock or unlock doors.
- *Vehicle finder*: Locate your vehicle in large areas, such as a crowded parking lot.
- *Security alarm notification*: If your vehicle's security system detects tampering, the provider notifies you.

■ Operator Assistance

Press LINK on the ceiling console to connect to an operator when trying to find a destination or for roadside assistance.



NAVIGATION*

Learn how to enter a destination and operate the navigation system.

Basic Navigation Operation

A real-time navigation system uses GPS and a map database to show your current location and help guide you to a desired destination. You can operate the system using voice commands or the system controls.

To reduce the potential for driver distraction, certain manual functions may be inoperable or grayed out while the vehicle is moving. Voice commands are always available.

■ Steering Wheel Controls

Use the steering wheel controls to give voice commands. For a full list of navigation voice commands, see page 151.

Hang-Up/Back button: Press to cancel a command or operation.

Talk button: Press to say navigation commands from the Voice Portal screen.

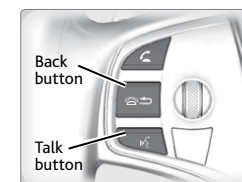

■ Talk Button Tips

- When using the Talk button, wait for the beep before saying a command.
- To bypass the system prompts, simply press the Talk button again to say your command.
- Speak in a clear, natural voice.
- Reduce all background noise.
- Adjust the dashboard vents away from the microphone in the ceiling.
- Close the windows and moonroof.

⚠ WARNING

Using the navigation system while driving can take your attention away from the road, causing a crash in which you could be seriously injured or killed. Only operate system controls when the conditions permit you to safely do so.

*if equipped

Navigation Display and Controls

Use the controls to enter information and make selections.

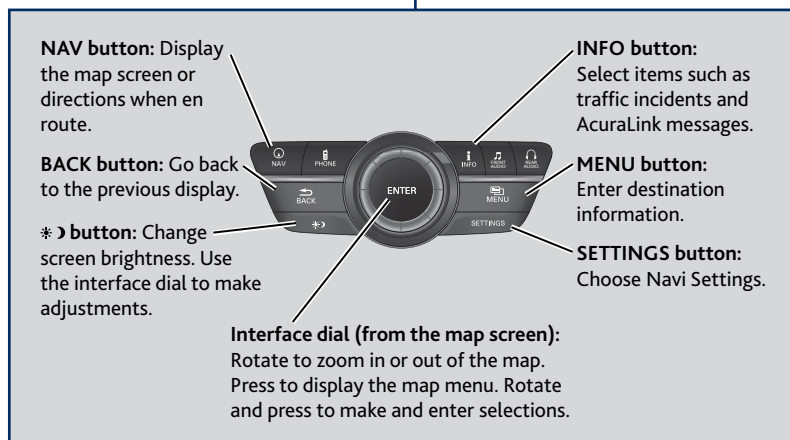
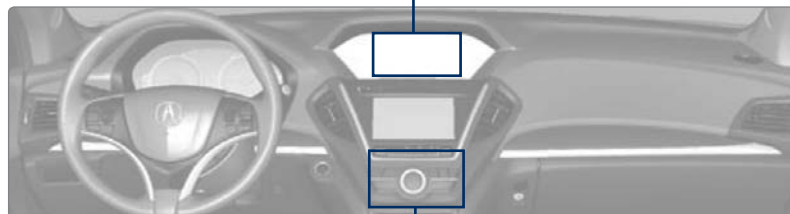
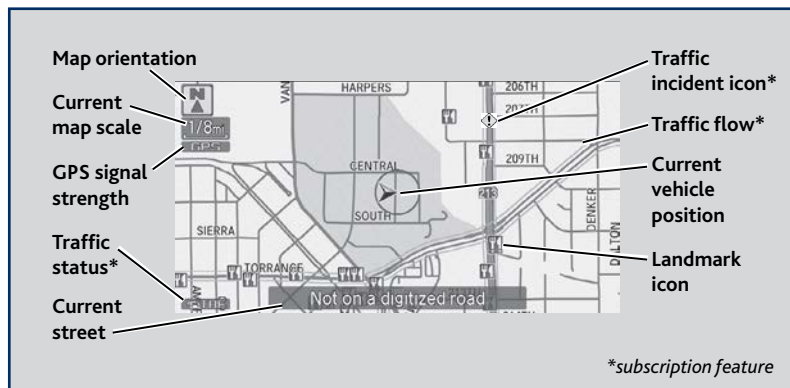

System Guidance Volume

Adjust the navigation system guidance volume. This does not affect audio or Bluetooth® HandsFreeLink® volume, which is controlled by the volume knob. Use the interface dial to make and enter selections.

1. From the map screen, press the interface dial to display the Map Menu.
2. Select Guidance Volume.
3. Adjust the volume to your preferred level.
4. Press BACK to exit the menu.



Voice Prompt

Turn the voice prompt feature on or off. Use the interface dial to make and enter selections.

1. Press SETTINGS.
2. Select System Settings.
3. Select Voice Rec.
4. Select Off or On.



- ON:** Provides voice prompts.
- OFF:** Voice prompts are disabled.

TABLE OF CONTENTS

VISUAL INDEX

SAFETY INFORMATION

INSTRUMENT PANEL

VEHICLE CONTROLS

AUDIO AND CONNECTIVITY

BLUETOOTH® HANDSFREELINK®

ACURALINK®

NAVIGATION

DRIVING

HANDLING THE UNEXPECTED

MAINTENANCE

SPECIFICATIONS

CLIENT INFORMATION

VOICE COMMAND INDEX

INDEX

Entering a Destination

Use several methods to enter a destination.

Home Address

Store your home address in the system so you can easily route to it. Use the interface dial to make and enter selections.

1. Press SETTINGS.
2. Select Navi Settings.
3. Select Personal Info.
4. Select Edit Go Home.
5. Enter the address and select OK.



When your home address is stored, you can press the Talk button and say "Navigation" and then "Go home" at any time. You can also select Go Home from the destination menu.

Street Address

Enter a street address using voice commands (U.S. models only). Press the Talk button to enter the Voice Portal screen.

You can also enter the address manually when the vehicle is stopped. While on the map screen, press MENU and use the interface dial to select Address. Follow the prompts.

1. From the Voice Portal screen, say "Navigation" and then "Address."
2. The system prompts you to say the entire address. For example, say "1-2-3-4 Main Street, Los Angeles, California."
3. The system interprets the address by state, city, street, and address number. If necessary, you may have to clarify similar matches.
4. Say "Set as destination" to set the route.

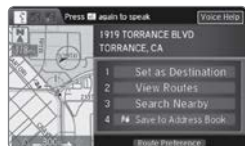

Place Category

Enter a point of interest using voice commands (U.S. models only). Press the Talk button to enter the Voice Portal screen

1. From the Voice Portal, say "Navigation" and then "Place name."
2. Say a category. For example, "ATM/Bank."
3. Say the name of the point of interest. For example, "ABC Bank."
4. The system interprets the name. If necessary, you may have to clarify similar matches. If there is more than one point of interest with the name, a list of matches appears in order of closest distance. Use the interface dial to select an entry.
5. Use the interface dial to select "Set as destination" to set the route.



You can also enter the place name manually when the vehicle is stopped. While on the map screen, press the MENU button and use the interface dial to select Place Name. Enter the name one letter at a time, and follow the prompts.

Find Nearest Place

Enter a destination by category and distance using voice commands. Press the Talk button to enter the Voice Portal screen.

1. Say "Navigation" and then "Find nearest POI category" and a place. For example, "Find nearest ATM."
2. A list of the nearest places in your area is displayed by shortest distance to destination.
3. Use the interface dial to select an entry.
4. Use the interface dial to select "Set as destination" to set the route.

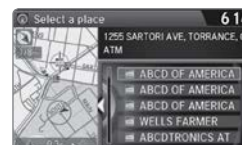

ODMD Shortcuts

You can add up to six destinations to the Shortcuts (Places tab) in the ODMD. The addresses must be previously stored in your navigation system address book.

1. Select Shortcuts.
2. Select Places.
3. Store a previously stored address book entry, or select the shortcut to route to it.



Routing

After a destination is set, you can alter or cancel your route.

Map Legend

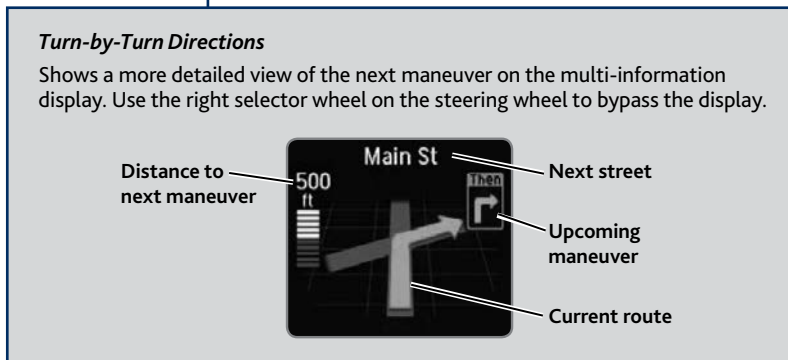
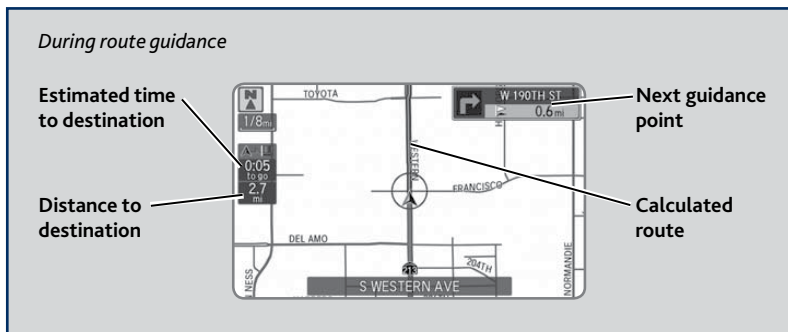

Taking a Detour

You can calculate a detour route manually if you encounter a road closure or other obstacle. Use the interface dial to make and enter selections.

1. When en route, press the MENU button.
2. Select Detour. The system attempts to calculate a new route by avoiding the next 5 miles (8 km) while on a freeway or 1 mile (1 km) while on a surface street.



AcuraLink Real-Time Traffic™*

View traffic flow, incidents, and construction in major metro areas. You can also route around congestion or incidents when a destination is set. Use the interface dial to make and enter selections. **Available in the U.S. only.**

1. From the map screen, press the interface dial to enter the map menu. Select Traffic Incidents.
2. A list of incidents on your route appears. Select the incident you want to avoid.
3. Select Avoid. Repeat as necessary to select other incidents.
4. Select Recalculate the Route.



Canceling Your Route

You can cancel your route at any time.

1. When en route, press the MENU button.
2. Select Cancel Route. The route is cleared and the map screen returns.



*Requires AcuraLink subscription. Visit owners.acura.com for more information.

DRIVING

Learn about preparation for driving, as well as other features.

Before Driving

Check the following items before you begin driving.

■ Exterior Checks

- Make sure there are no obstructions on the windows, door mirrors, exterior lights, or other parts of the vehicle.
- Remove any frost, snow, or ice.
- Make sure the hood is securely closed.
- Heat from the engine and exhaust can ignite flammable materials left under the hood, causing a fire. If you've parked your vehicle for an extended period, inspect and remove any debris that may have collected, such as dried grass and leaves that have fallen or have been carried in for use as a nest by a small animal. Also check under the hood for leftover flammable materials after you or someone else has performed maintenance on your vehicle.
- Make sure the tires are in good condition.
- Make sure there are no people or objects behind or around the vehicle.

NOTICE

If the doors are frozen shut, use warm water around the door edges to melt any ice. Do not try to force them open, as this can damage the rubber trim around the doors. When done, wipe dry to avoid further freezing.

■ Interior Checks

- Store or secure all items on board properly.
- Do not pile items higher than the seat height.
- Do not place anything in the front seat footwells. Make sure to secure the floor mats.
- If you have any animals on board, do not let them move freely in the vehicle.
- Securely close and lock all doors and the tailgate.
- Adjust your seating position, mirrors, and steering wheel properly.
- Make sure items placed on the floor behind the front seats cannot roll under the seats.
- Everyone in the vehicle must fasten their seat belt.
- Make sure that the indicators in the instrument panel come on when you start the vehicle, and go off soon after.

■ Driving Guidelines for Your Utility Vehicle

Utility vehicles have a significantly higher rollover rate than other types of vehicles. To prevent rollovers or loss of control:

- Take corners at slower speeds than you would with a passenger vehicle.
- Avoid sharp turns and abrupt maneuvers whenever possible.
- Do not modify your vehicle in any way that raises its center of gravity.
- Never carry more than 165 lbs (75 kg) of cargo on the roof rack (Acura accessory).

In addition:

- During the first 600 miles (1,000 km) of operation, avoid sudden acceleration or full throttle operation so as not to damage the engine or powertrain.
- Avoid hard braking for the first 200 miles (300 km). You should also follow this when the brake pads are replaced.

⚠ WARNING

Improperly operating this vehicle on or off pavement can cause crash or rollover in which you and your passengers can be seriously injured or killed. Follow all instructions and guidelines in this guide. Keep your speed low, and don't drive faster than conditions permit.

⚠ WARNING

Improper accessories or modifications can affect your vehicle's handling, stability, and performance, and cause a crash in which you can be seriously hurt or killed. Follow all instructions in the vehicle owner's manual regarding accessories and modifications.

Maximum Load Limit

Carrying too much cargo or improperly storing it can affect your vehicle's handling, stability, stopping distance, and tires, and make it unsafe.

The maximum load for your vehicle is 1,173 lbs (532 kg). See the Tire and Loading Information label on the driver's doorjamb.

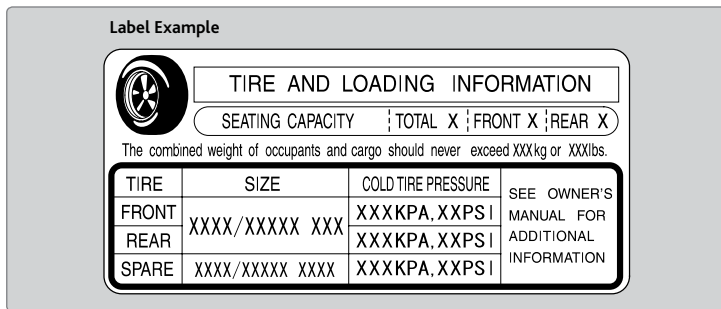

This figure includes the total weight of all occupants, cargo, and accessories, and the tongue load if you are towing a trailer. Below are the steps for determining the correct load limit:

1. Locate the statement "The combined weight of occupants and cargo should never exceed XXX kg or XXX lbs." on your vehicle's placard.
2. Determine the combined weight of the driver and passengers that will be riding in your vehicle.
3. Subtract the combined weight of the driver and passengers from XXX kg or XXX lbs.
4. The resulting figure equals the available amount of cargo and luggage load capacity. For example, if the "XXX" amount equals 1,400 lbs. and there will be five 150 lb. passengers in your vehicle, the amount of available cargo and luggage load capacity is 650 lbs. (1,400 - 750 (5 x 150) = 650 lbs.)
5. Determine the combined weight of luggage and cargo being loaded on the vehicle. That weight may not safely exceed the available cargo and luggage load capacity calculated in step 4.
6. If your vehicle will be towing a trailer, load from your trailer will be transferred to your vehicle. Consult the Owner's Manual on the Owner Information CD or at owners.acura.com to determine how this reduces the available cargo and luggage load capacity of your vehicle.

In addition, the total weight of the vehicle, all occupants, accessories, cargo, and trailer tongue load must not exceed the Gross Vehicle Weight Rating (GVWR) or the Gross Axle Weight Rating (GAWR). Both are on a label on the driver's doorjamb.

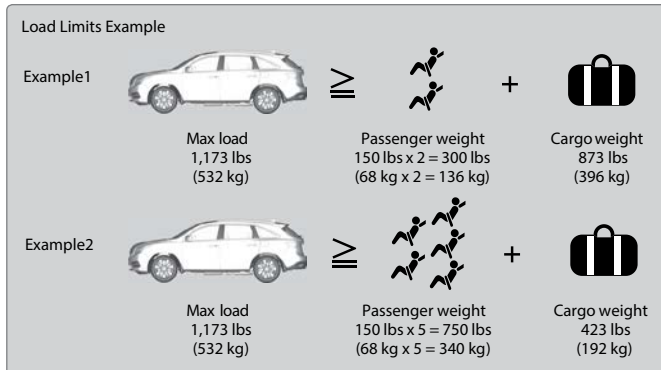

⚠ WARNING

Overloading or improper loading can affect handling and stability and cause a crash in which you can be hurt or killed.

Follow all load limits and other loading guidelines in this manual.

The headlight aim on your vehicle was set by the factory, and does not need to be adjusted. However, if you regularly carry heavy items in the cargo area or pull a trailer, have the aiming readjusted at your dealer or by a qualified technician.

Towing a Trailer

Your vehicle can tow a trailer if you carefully observe the load limits, use the proper equipment, and follow the towing guidelines. An accessory front towing grille is required whenever a trailer is towed. You can get the accessory grille at a dealer. See the Owner's Manual on the Owner Information CD or visit owners.acura.com for more information.

Towing Load Limits

Total trailer weight

Do not exceed the maximum allowable weight of the trailer, cargo, and everything in or on it shown in the table below.

Towing loads in excess of this can seriously affect vehicle handling and performance and can damage the engine and drivetrain.

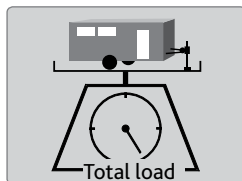

Number of occupants	4WD models with ATF cooler	4WD models without ATF cooler	2WD models
2	5,000 lbs (2,268 kg)	3,500 lbs (1,588 kg)	3,500 lbs (1,588 kg)
3	4,750 lbs (2,155 kg)	3,250 lbs (1,474 kg)	3,250 lbs (1,474 kg)
4	4,500 lbs (2,041 kg)	3,000 lbs (1,361 kg)	3,000 lbs (1,361 kg)
5	4,250 lbs (1,928 kg)	2,750 lbs (1,247 kg)	2,750 lbs (1,247 kg)
6	4,000 lbs (1,814 kg)	2,500 lbs (1,134 kg)	2,500 lbs (1,134 kg)
7	Towing not recommended		

Each weight limit is calculated based on the following conditions:

- Occupants fill seats from the front of the vehicle to the back.
- Each occupant weights 150 lbs (68 kg).
- Each occupant has 15 lbs (7 kg) of cargo in the cargo area.

Any additional weight, cargo or accessories reduce the maximum trailer weight and maximum tongue load.

Tongue load

The weight of the tongue with a fully loaded trailer on the hitch should be approximately:

Boat trailers: 5-15% of the total trailer weight.

Other trailers: 10-15% of total trailer weight.

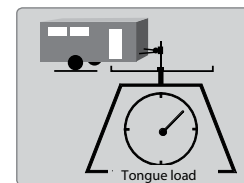

Number of occupants	4WD models with or ATF cooler	2WD models
2	500 lbs (227 kg)	350 lbs (159 kg)
3	475 lbs (215 kg)	325 lbs (147 kg)
4	380 lbs (172 kg)	300 lbs (136 kg)
5	290 lbs (132 kg)	275 lbs (125 kg)
6	165 lbs (75 kg)	150 lbs (68 kg)
7	Towing not recommended	

Estimate tongue load

Excessive tongue load reduces front tire traction and steering control. Too little tongue load can make the trailer unstable and cause it to sway.

You can estimate the tongue load by measuring the trailer hitch height from the ground in the following steps:

1. Park the vehicle on level ground.
2. Measure the distance between the ground and the bottom of the trailer hitch.
3. Connect the fully loaded trailer to the hitch.
4. Measure the distance between the ground and the bottom of the trailer hitch again.
5. Subtract the second measurement from the first measurement, then refer to the following table.

If the difference is	4WD models	2WD models
1 inches (2.5 cm)	150 lbs (68 kg)	
1 1/2 inches (3.8 cm)	250 lbs (114 kg)	
2 inches (5.1 cm)	350 lbs (159 kg)	
2 3/8 inches (6.0 cm)	450 lbs (205 kg)	—
2 5/8 inches (6.7 cm)	500 lbs (227 kg)	—

If the difference becomes more than indicated in the table, distribute the load or remove cargo as needed.

Weigh trailer loads using a public scale

Check each weight in the order indicated as shown.

Refer to the table below for each weight's limit except for the tongue load.

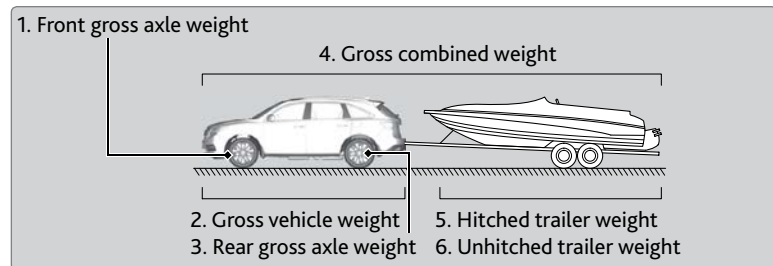

- If you cannot weigh the rear axle, subtract 1 from 2.
- The maximum gross combined weight (4) decreases by 2% for every 1,000 feet (305 meters) of elevation.
- To calculate the tongue load, subtract 5 from 6.
- Refer to the trailer owner's manual for additional information.

Weight limit for	2WD models	4WD models
Front gross axle	2,811 lbs (1,275 kg)	2,910 lbs (1,320 kg)
Gross vehicle	5,368 lbs (2,435 kg)	5,677 lbs (2,575 kg)
Rear gross axle	2,734 lbs (1,240 kg)	2,965 lbs (1,345 kg)
Gross combined	8,036 lbs (3,645 kg)	9,833 lbs (4,460 kg)

■ Pre-Tow Checklist

When preparing to tow, and before driving away, be sure to check the following:

- Avoid towing a trailer during your vehicle's first 600 miles (1,000 km).
- The vehicle and trailer have been properly serviced and are in good condition. Lights and brakes work properly, and the tires are properly inflated.
- All weights and loads are within limits. Never exceed the gross weight ratings.
- When towing more than 3,500 lbs (1,590 kg), use of gasoline with an octane rating of 91 or higher is recommended.
- Check if all loads are within limits at a public scale (see page 90). If a public scale is not available, add the estimated weight of your cargo load to the weight of the trailer (as quoted by the manufacturer) and the tongue load.
- The hitch, safety chains, and any other attachments are secure.
- All items in or on the trailer are properly secured and cannot shift while you drive.

⚠️ WARNING

Exceeding any load limit or improperly loading your vehicle and trailer can cause a crash in which you can be seriously hurt or killed.
Check the loading of your vehicle and trailer carefully before starting to drive.

TABLE OF CONTENTS

VISUAL INDEX

SAFETY INFORMATION

INSTRUMENT PANEL

VEHICLE CONTROLS

AUDIO AND CONNECTIVITY

BLUETOOTH® HANDSFREELINK®

ACURALINK®

NAVIGATION

DRIVING

HANDLING THE UNEXPECTED

MAINTENANCE

SPECIFICATIONS

CLIENT INFORMATION

VOICE COMMAND INDEX

INDEX

Remote Engine Start*

Start your vehicle's engine from extended distances using the two-way remote transmitter before you enter the vehicle.

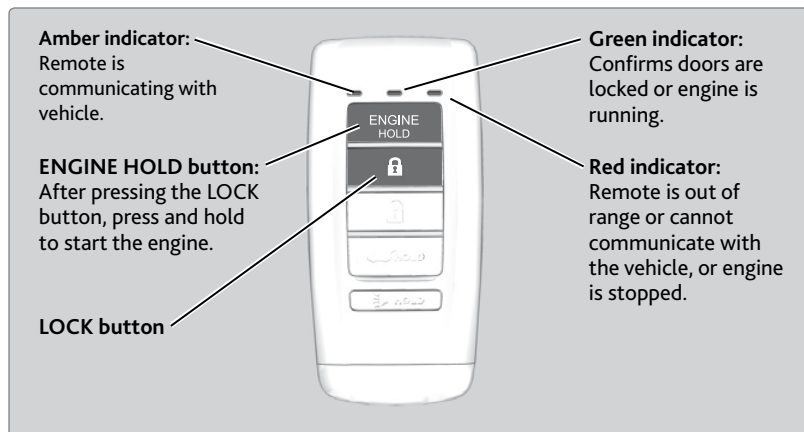

Make sure the vehicle is in a safe location when using remote engine start (i.e., a well ventilated area, away from any flammable materials).

Starting the Engine

Press the LOCK button, then press and hold the ENGINE HOLD button to remotely start the engine.

The engine runs for up to 10 minutes. To extend the run time for another 10 minutes, repeat the procedure during the initial 10 minutes.

While the engine is running, the climate control system adjusts the cabin temperature, the security system remains on, and lights and accessories remain off.

Stopping the Engine

Press and hold ENGINE.

The engine will also stop if it has been running for more than 10 minutes, or if any door is opened without using the remote or keyless access.

WARNING

Engine exhaust contains toxic carbon monoxide gas.

Breathing carbon monoxide can kill you or cause unconsciousness.

Never use the remote engine starter when the vehicle is parked in a garage or other area with limited ventilation.

*if equipped

Starting to Drive

The keyless access system allows simple push-button start.

Before Starting the Engine

Make sure the gear is in Park (P) and the parking brake is released, then depress the brake pedal. Keep your foot firmly on the brake pedal when starting the engine.

The engine is harder to start in cold weather and in thinner air found at altitudes above 8,000 feet (2,400 m). When starting the engine in cold weather, turn off all electrical accessories such as the lights, climate control system, and rear defogger in order to reduce battery drain.

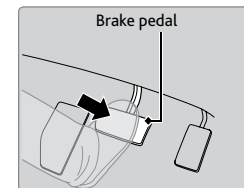

Changing the Power Mode

Accessory or On Mode: Press ENGINE START/STOP once without pressing the brake pedal for Accessory mode. Press it again for On mode.

Starting the engine: Press and hold the brake pedal, then press ENGINE START/STOP. Keep your foot firmly on the brake pedal when starting the engine.

Turning the vehicle off: Change the gear to Park (P), then press ENGINE START/STOP. If you press the button and the gear is not in Park, the vehicle goes into Accessory mode.



Shifting

Change your vehicle's gears to begin driving.

■ Electronic Gear Selector

Select the vehicle's gear using a simple button interface.

Park (P): Used for parking or starting or turning off the vehicle. Press P with the brake pedal pressed. A red indicator appears.



Reverse (R): Used for reversing. Pull back R. A green indicator appears.

Neutral (N): Used for idling. Press N. A red indicator appears

Drive (D/S): Used for normal driving (D) or driving in sequential mode (S) (see page 95). Press D/S once for normal driving. Press D/S twice for sequential mode driving. A green indicator appears. Make sure the parking brake is released (see page 98).

⚠ WARNING

The vehicle can roll away if left unattended without confirming that Park is engaged. Always keep your foot on the brake pedal until you have confirmed that P is shown on the gear position indicator.

NOTICE

When you change from D to R and vice versa, press the brake pedal and come to a complete stop, then select the intended gear position while maintaining brake pressure.

Auto park mode

For your convenience, Park (P) is automatically selected when all of the following conditions are met:

- The vehicle is stopped.
- The driver's seatbelt is unbuckled.
- The driver's door is opened.

Car wash mode

If you are driving through a conveyor-style car wash where you or the attendant do not remain in the vehicle, follow these steps while the engine is on:

1. Press and hold the brake pedal.
2. Select N.
3. Within 5 seconds, press the ENGINE START/STOP button. The gear position remains in Neutral with the power mode in Accessory for 15 minutes. After 15 minutes (or if the vehicle is turned off at any time), the gear position changes to Park and the vehicle turns off.

■ Sequential Mode

Use the paddle shifters to change gears from 1st through 9th without removing your hands from the steering wheel.

Recommended shift points	
Shift up	Normal acceleration
1st to 2nd	15 mph (24 km/h)
2nd to 3rd	25 mph (40 km/h)
3rd to 4th	40 mph (64 km/h)
4th to 5th	47 mph (76 km/h)
5th to 6th	52 mph (84 km/h)
6th to 7th	57 mph (92 km/h)
7th to 8th	62 mph (100 km/h)
8th to 9th	67 mph (108 km/h)

(-) Paddle shifter: Pull to shift down to a lower gear.

(+) Paddle shifter: Pull to shift up to a higher gear.

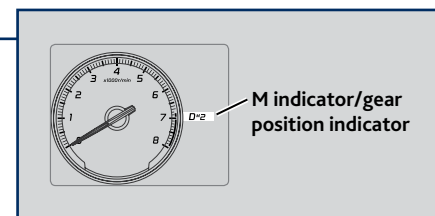
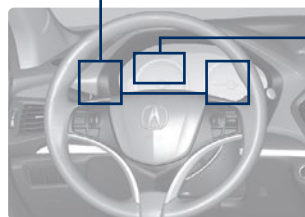

When the transmission is in D: The vehicle goes into sequential shift mode momentarily, and the gear position indicator comes on. When you start traveling at a constant speed, sequential mode and the gear position indicator automatically go off.

When the transmission is in S: The vehicle goes into sequential mode, and the M (sequential mode) indicator and gear position indicator come on. Use the paddle shifters to change gears.

To cancel this mode, hold the + paddle shifter for two seconds. The M indicator and gear position indicator go off.

Auto Idle Stop*

Automatically stops and restarts the engine to help maximize fuel economy, depending on environmental and vehicle conditions.

■ Activating Auto Idle Stop

When the vehicle stops with the gear position in Drive (D) and the brake pedal is pressed, the engine turns off and the auto idle stop indicator appears if conditions permit.



When you release the brake pedal, turn the steering wheel, or press the accelerator pedal, the engine restarts and the vehicle begins to move.

Auto idle stop does not activate (or the engine may automatically restart) when the driver's seat belt is unfastened, the vehicle is stopped on a steep hill, the windshield defroster is on, and other conditions.

■ Turning the System On or Off

Press the Auto Idle Stop Off button to turn the system off. Press the button again to turn it on.



*if equipped

Integrated Dynamics System (IDS)

Choose a driving mode for your preference based on road conditions, vehicle speed, and handling.

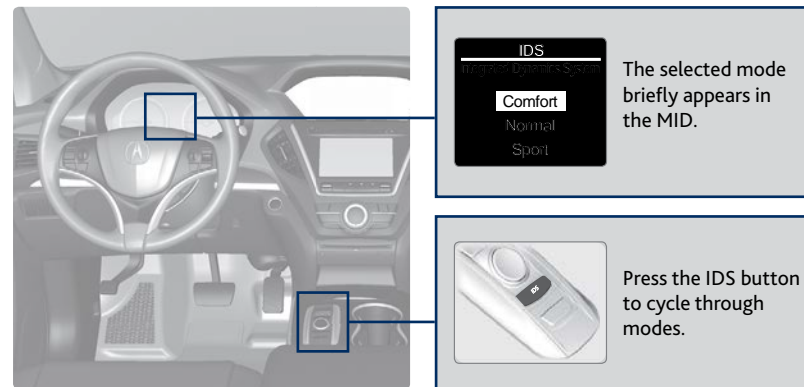

Comfort: Maximizes driver comfort through increased steering assist.

Normal: Balances performance for everyday driving.

Sport: Enhances vehicle response and feel through decreased steering assist and increased throttle and torque.

Vehicle Stability Assist (VSA®), aka Electronic Stability Control (ESC) System

Helps to stabilize the vehicle during cornering if the vehicle turns more or less than what was intended. It assists in maintaining traction on slippery surfaces by regulating engine output and selectively applying the brakes.

■ Turning VSA On or Off

VSA is turned on every time you start the vehicle. If you turn VSA off, your vehicle has normal braking and cornering ability, but VSA traction and stability enhancement become less effective.

Press and hold the VSA OFF button until you hear a beep to turn VSA on or off. The VSA Off indicator appears when the system is off.

When VSA is off, traction control stops functioning, which allows the wheels to spin more freely at low speed. This can be helpful when trying to free your vehicle if it is stuck in mud or snow.

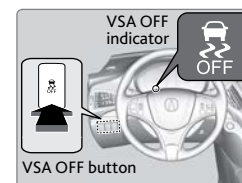

Braking

Slow down or stop your vehicle, and keep it from moving when parked.

■ Foot Brake

Press the brake pedal to slow down or stop your vehicle from moving.

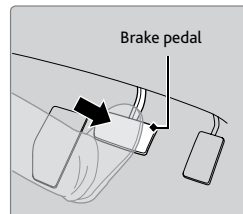

■ Brake Assist System

During hard or emergency braking, the system increases braking force. The brake pedal may move slightly or make a noise; this is normal. Continue to hold the brake pedal firmly down.

■ Anti-Lock Brake System (ABS)

During hard or emergency braking, the system rapidly pumps the brakes to prevent wheel lockup and help you maintain steering control. The brake pedal may pulsate slightly during ABS operation; this is normal. Do not pump the brake pedal, and continue to hold it firmly down.

NOTICE

The ABS may not function correctly if you use an incorrect tire type and size.

■ Parking Brake

Keep the vehicle from moving when it is parked.

To apply: Press the parking brake with your foot.

To release: Press the brake pedal, then press the parking brake until it releases.

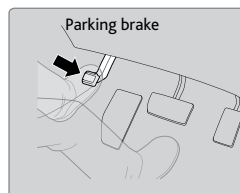

NOTICE

Release the parking brake fully before driving. The rear brakes and axle can be damaged if you drive with the parking brake applied.

Cruise Control*

Maintain a constant vehicle speed without having to keep your foot on the accelerator pedal. Use cruise control on freeways or open roads where you can travel at a constant speed with little acceleration or deceleration.

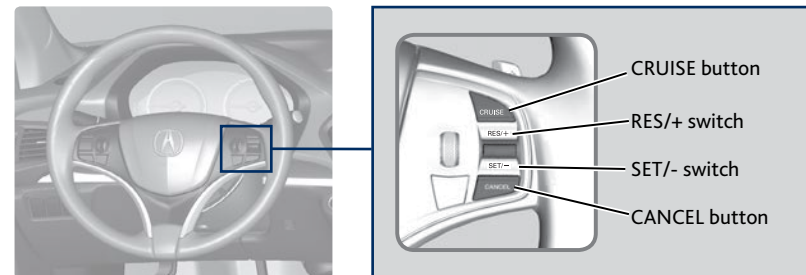

■ Activating and Setting the Vehicle Speed

1. Press CRUISE. The CRUISE MAIN indicator appears.
2. Accelerate to the desired speed (above 25 mph/40 km/h). Take your foot off the accelerator pedal, and press SET/- to set the speed. The CRUISE CONTROL indicator appears.



■ Adjusting the Vehicle Speed

Press RES/+ to increase speed or SET/- to decrease speed.

Each time you press the button, the vehicle speed is increased or decreased by about 1 mph (1 km/h). If you keep the button pressed, the vehicle speed increases or decreases until you release it.

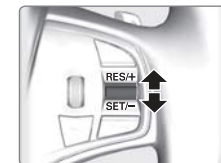

■ Canceling Cruise Control

Press CANCEL or the brake pedal. The CRUISE CONTROL indicator goes off.

After cruise control has been canceled, you can still resume the prior set speed by pressing RES/+ while driving at a speed of at least 25 mph (40 km/h).

Press CRUISE to turn the system off.



⚠ WARNING

Improper use of the cruise control can lead to a crash.

Use cruise control only when traveling on open highways in good weather.

*if equipped

Adaptive Cruise Control (ACC) with Low Speed Follow*

Helps maintain a constant vehicle speed and a set following interval behind a vehicle detected ahead of yours.



■ Activating and Setting the Vehicle Speed

1. Press MAIN. The ACC indicator appears.
2. Accelerate to the desired speed.

Above 25 mph/40 km/h: Take your foot off the accelerator pedal, and press SET/- to set the speed.

Below 25 mph/40 km/h (Low Speed Follow): Press SET/- to set the speed at 25 mph/40 km/h when there is a vehicle ahead of you.



■ Adjusting the Vehicle Speed

Press RES/+ to increase speed or SET/- to decrease speed.

Each time you press the switch up or down, the vehicle speed is increased or decreased by about 1 km/h. If you keep the switch pressed up or down, the vehicle speed increases or decreases by 8 km/h until you release it.

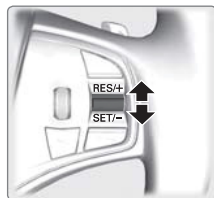

■ Adjusting the Following Distance

Press the Distance button to change the following distance. Each time you press the button, the following distance cycles through short, middle, long, and extra long.



■ Switching to Standard Cruise Control

Press and hold the Distance button.

*if equipped

■ During Operation

If a vehicle detected ahead of you slows down abruptly, or if another vehicle cuts in front of you, a beep sounds and BRAKE appears on the multi-information display to alert you.

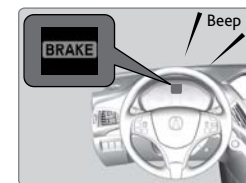

When a vehicle detected ahead is within ACC with low speed follow range and stops, your vehicle also stops. The Stopped message appears on the multi-information display.

When the vehicle ahead of you starts again, the vehicle icon on the multi-information display blinks. Press RES/+ / SET/- up or down, or depress the accelerator pedal to resume the prior set speed.

If your vehicle is stationary and there is no vehicle detected ahead of you, the system cancels and a beep sounds.

⚠ WARNING

Exiting a vehicle that has been stopped while the ACC with LSF system is operating can result in the vehicle moving without operator control. Always make sure the gear is in Park (P) before exiting the vehicle.

A vehicle that moves without operator control can cause a crash, resulting in serious injury or death.

Never exit a vehicle when the vehicle is stopped by ACC with LSF.

⚠ WARNING

ACC with LSF has limited braking capability and may not stop your vehicle in time to avoid a collision with a vehicle that quickly stops in front of you.

Always be prepared to apply the brake pedal if conditions require.

■ Canceling ACC

You can press CANCEL, press MAIN, or depress the brake pedal. The ACC indicator goes off.

Certain conditions may cause ACC to cancel automatically. When this happens, a beep sounds and a message appears on the multi-information display.

After cruise control has been canceled, you can still resume the prior set speed by pressing RES/+.



⚠ WARNING

Improper use of ACC with LSF can lead to a crash.

Use ACC with LSF only when driving on expressways or freeways and in good weather conditions.

Forward Collision Warning (FCW) with Pedestrian Detection*

Alerts you if the system determines the possibility of your vehicle colliding with a vehicle detected in front of you when your vehicle speed is 10 mph (15 km/h) or higher, or a pedestrian is detected in front of you when your vehicle speed is between 10–62 mph (15–100 km/h).

If you do not brake in time or take preventive action, BRAKE flashes in the MID and a beep sounds continuously.

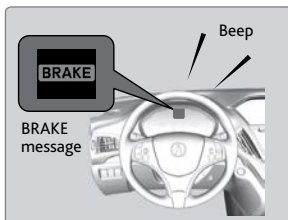

■ Changing Settings

Determine the warning timing, or turn the system off. Use the interface dial to make and enter selections.

1. Press SETTINGS.
2. Select Vehicle Settings.
3. Select Forward Collision Warning Distance.
4. Select Long, Normal, Short, or Off.
5. Press BACK to exit the menu.

Important Safety Reminder

FCW with Pedestrian Detection cannot detect all objects ahead and may not detect a given object; accuracy of the system will vary based on weather, speed, extreme interior heat, and other factors. The system does not include a braking function. It is always your responsibility to safely operate the vehicle and avoid collisions.

**if equipped*

Collision Mitigation Braking System™ (CMBS™)*

Can assist you when there is a possibility of your vehicle colliding with a vehicle or a pedestrian detected in front of yours.

The system can alert you when a potential collision is determined, and reduce your vehicle speed to help minimize collision severity when a collision is deemed unavoidable.



The system activates when:

- The speed difference between your vehicle and a vehicle or pedestrian detected in front of you is about 3 mph (5 km/h) and over with a chance of a collision.
- Your vehicle speed is about 62 mph (100 km/h) or less and there is a chance of a collision with an oncoming detected vehicle or a pedestrian in front of you.

■ Alert Stages

The system has three alert stages for a possible collision. Depending on the circumstances or CMBS settings, CMBS may not go through all of the stages before initiating the last stage.

Stage 1: Head-up warning and beep

Stage 2: Head-up warning, beep, light seat belt retraction, and light brake application

Stage 3: Head-up warning, beep, strong seat belt retraction, and strong brake application

■ Changing Settings

Determine the warning timing. Use the interface dial to make and enter selections.

1. Press SETTINGS.
2. Select Vehicle Settings.
3. Select Forward Collision Warning Distance.
4. Select Long, Normal, or Short.
5. Press BACK to exit the menu.



**if equipped*

■ Turning CMBS On or Off

Press and hold CMBS OFF. A beep sounds and a message appears in the MID. The CMBS indicator appears when the system is off.



Important Safety Reminder

CMBS is designed to reduce the severity of an unavoidable collision. It does not prevent collisions nor stop the vehicle automatically. It is still your responsibility to operate the brake pedal and steering wheel appropriately according to the driving conditions.

Lane Departure Warning (LDW)*

Alerts you if the system detects a possibility of your vehicle unintentionally crossing over detected lane markings while driving between 45–90 mph (72–145 km/h).

If your vehicle is getting too close to detected left or right side lane markings without a turn signal activated, the system provides visual and tactile alerts.

A Lane Departure message appears on the MID, and the steering wheel vibrates. Take appropriate action to stay within your driving lane.



■ Turning LDW On or Off

Press the LDW button to turn the system on or off. A green indicator light appears on the button when the system is on.



Important Safety Reminder

Like all assistance systems, LDW has limitations. Over-reliance on LDW may result in a collision. It is always your responsibility to keep the vehicle within your lane.

LDW only alerts you when lane drift is detected without a turn signal in use. LDW may not detect all lane markings or lane departures; accuracy will vary based on weather, speed, and lane marker condition. It is always your responsibility to safely operate the vehicle and avoid collisions.

*if equipped

Lane Keeping Assist System (LKAS)*

Provides steering input to help keep the vehicle in the middle of a detected lane and visual and tactile alerts if the vehicle is detected drifting out of its lane while driving between 45–90 mph (72–145 km/h).

If your vehicle is getting too close to detected left or right side lane markings without a turn signal activated, the system provides visual and tactile alerts.

A Lane Departure message appears on the MID, and the steering wheel vibrates. Steering torque is also applied to help keep your vehicle within your driving lane. Take appropriate action to stay within your driving lane.

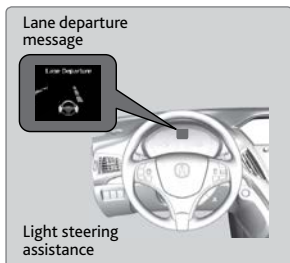

Turning LKAS On or Off

1. Press MAIN. LKAS appears in the MID.
2. Press the LKAS button. Lane outlines appear in the MID. Dotted lane lines turn solid when the system operates.
3. Press MAIN or the LKAS button to turn the system off.

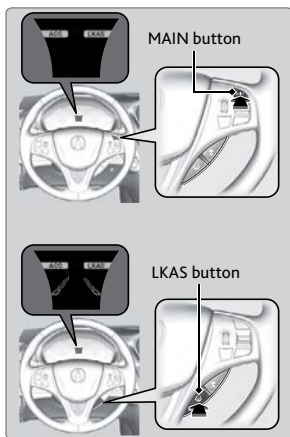

Important Safety Reminder

LKAS is for your convenience only. It is not a substitute for your vehicle control. The system does not work if you take your hands off the steering wheel or fail to steer the vehicle.

Do not place an object on the top of the instrument panel. It may reflect onto the windshield and prevent the system from detecting lane lines properly.

Do not use when towing.

*if equipped

Road Departure Mitigation (RDM)*

Alerts and helps to assist you if the system determines a possibility of your vehicle unintentionally crossing over detected lane markings while driving between 45–90 mph (72–145 km/h).

If your vehicle is getting too close to detected lane markings without a turn signal activated, a message appears in the MID. Steering wheel torque and vibrations are applied to help your vehicle stay in the lane.

Braking may also be applied if the lane lines are solid and continuous.

If the system operates several times without detecting driver response, the system beeps to alert you.

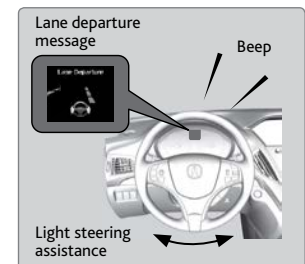

Turning the System On or Off

Press the RDM button to turn the system on or off. A green indicator appears on the button when the system is on.

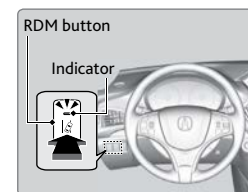

Changing Settings

Determine the warning timing, or turn the system off. Use the interface dial to make selections.

1. Press SETTINGS.
2. Select Vehicle Settings. The vehicle must be in Park (P).
3. Select Road Departure Mitigation Setting.
4. Select from the options.



Normal (default): Steering control starts from inside the lane edge.

Wide: Steering control starts from outside the lane edge.

Warning Only: The system only provides a BRAKE message, but does not apply steering or braking.

5. Press BACK to exit the menu.

Important Safety Reminder

The system has limitations. Overreliance on it may result in a collision. It is always your responsibility to keep your vehicle within the driving lane.

*if equipped

Blind Spot Information (BSI)*

Alerts you to a detected vehicle in your left or right blind spot while driving 20 mph (32 km/h) or higher.

When a vehicle is detected in your blind spot, the blind spot indicator turns on and stays lit until the area is clear.

When your turn signal is on and a vehicle is detected, the blind spot indicator blinks and a beep sounds until the area is clear or the turn signal is off.

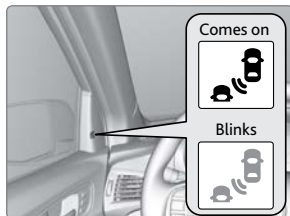

■ Changing Settings

Change the alert type, or turn the system on or off. Use the interface dial to make and enter selections.

1. Press SETTINGS.
2. Select Vehicle Settings.
3. Select Blind Spot Info.
4. Select an alert type, or Off.
5. Press BACK to exit the menu.



⚠ WARNING

Failure to visually confirm that it is safe to change lanes before doing so may result in a crash and serious injury or death. Do not rely only on the blind spot information system when changing lanes.

Always look in your mirrors, to either side of your vehicle, and behind you for other vehicles before changing lanes.

Important Safety Reminder

Like all assistance systems, BSI has limitations. Over-reliance on BSI may result in a collision. The system is for your convenience only.

*if equipped

Parking Sensor System*

When the system senses an object when you are parking or backing up, an indicator appears on the upper display and a series of beeps will sound. As you get closer to the object, the beep rate increases.

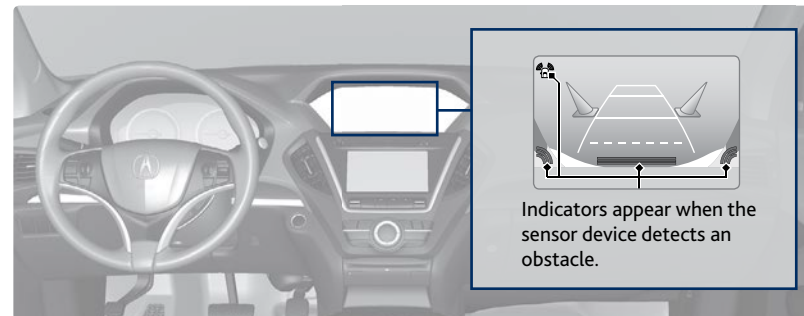

■ Turning the System On or Off

Press the parking sensor button. A green indicator light appears on the button when the system is on.

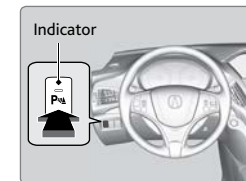

*if equipped

Multi-View Rear Camera*

When you change the gear to Reverse (R), a real-time image of the area behind your vehicle is shown in the display, along with helpful parking guidelines.

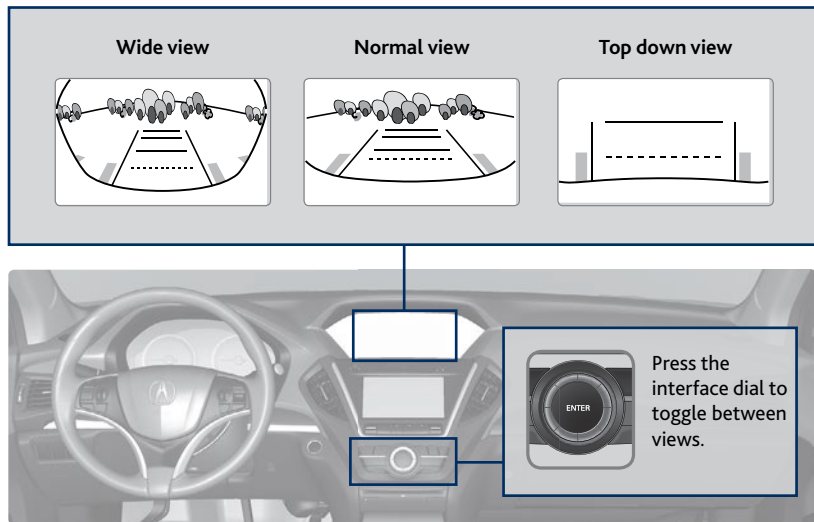

■ Changing Guidelines

Turn the guidelines on or off. Use the interface dial to make and enter selections.

1. Press SETTINGS.
2. Select Camera Settings
3. Select one of the options.

Fixed Guidelines: Guidelines appear when you change the gear to Reverse. Select On or Off.

Dynamic Guidelines: Guidelines move as you turn the steering wheel. Select On or Off.

4. Press BACK to exit the menu.



The rear camera view is restricted. You cannot see the corner ends of the bumper or what is underneath the bumper. Its unique lens also makes objects appear closer or farther than they actually are.

Visually confirm that it is safe to drive before backing up. Certain conditions (such as weather, lighting, and high temperatures) may also restrict the rear view. Do not rely on the rearview display, which does not give you all information about conditions at the rear of your vehicle.

*if equipped

Rear Cross Traffic Monitor*

Alerts you if a detected vehicle is approaching from a rear corner when your vehicle is in Reverse (R) at speeds of 3 mph (5 km/h) or lower, which can be helpful when backing out of parking spaces.

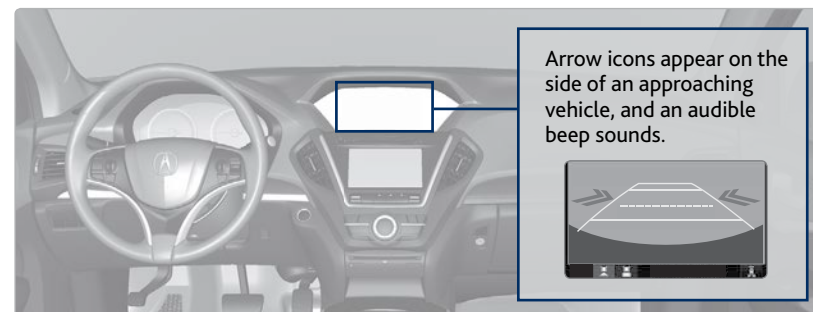

The system does not provide alerts for a vehicle that is moving away from your vehicle, and it may not detect pedestrians, bicycles, or stationary objects.

■ Turning the System On or Off

1. Press SETTINGS.
2. Select Camera Settings.
3. Select Cross Traffic Monitor.
4. Select On or Off.
5. Press BACK to exit the menu.



⚠ CAUTION

This system cannot detect all approaching vehicles and may not detect an approaching vehicle at all.

Failure to visually confirm that it is safe to back up the vehicle before doing so may result in a collision.

Do not solely rely on the system when reversing; always also use your mirrors, and look behind and to the sides of your vehicle before reversing.

*if equipped

Surround View Camera*

Four cameras assist in helping you view blind spots around the vehicle.

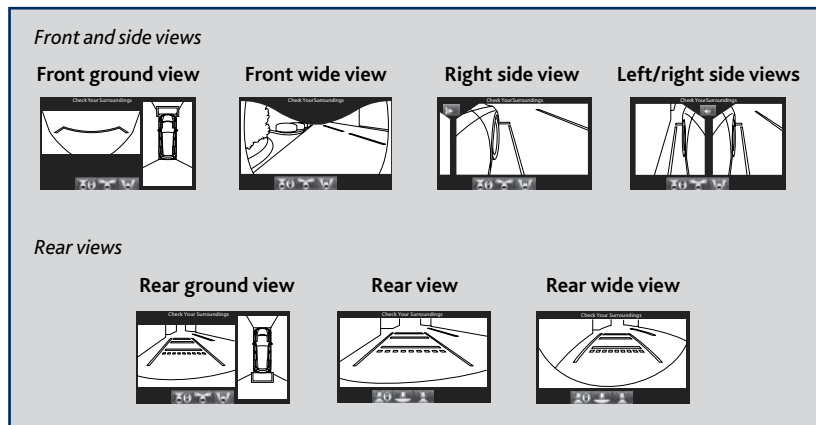

■ Displaying Front or Side Views

Press the CAMERA button when the vehicle is stationary or moving at 12 mph (20 km/h) or less. Press the button again or the interface dial to switch camera views.

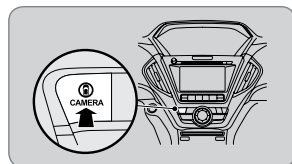

■ Displaying the Rear View

Change the gear to Reverse (R) to display the rear view. Press CAMERA or the interface dial to switch rear views.

The surround view camera does not eliminate all blind spots. Visually confirm safety around the vehicle with your own eyes and the mirrors. Do not rely on the camera view.

**if equipped (Canadian models)*

■ Changing Camera Settings

Use the interface dial to make and enter selections.

1. Press SETTINGS.
2. Select Camera Settings.
3. Select MCVS.
4. Select one of the options:
Guidelines: Turn guidelines on or off.
Preferences: Choose additional settings.
5. Select an option to make your preferred changes.
6. Press BACK to exit the menu.



⚠ WARNING

Failure to visually assess the area around the vehicle (directly or by use of the mirrors) may result in a crash causing serious injury or death.

The areas shown in the surround view camera system display are limited. The display may not show all pedestrians or other objects around your vehicle.

Do not solely rely only on the surround view camera system display to assess whether it is safe to move your vehicle.

⚠ WARNING

Failure to pay proper attention to your surroundings while driving may result in a crash causing serious injury or death.

To help mitigate the chances of a collision, only look at the surround view camera system display when it is safe to do so.

Refueling

Use the proper fuel and refueling procedure to ensure the best performance and safety of your vehicle.

Fuel Information

Use of unleaded premium gasoline of 91 octane or higher is recommended.

- Acura recommends TOP TIER Detergent Gasoline where available.
- Do NOT use gasoline containing more than 15% ethanol.
- Do NOT use gasoline containing methanol.
- Do NOT use gasoline containing MMT.

NOTICE

We recommend quality gasoline containing detergent additives that help prevent fuel system and engine deposits. In addition, in order to maintain good performance, fuel economy, and emissions control, we strongly recommend the use of gasoline that does NOT contain harmful manganese-based fuel additives such as MMT, if such gasoline is available.

How to Refuel

1. The fuel fill door is located at the left rear of the vehicle. Park next to the service pump that is most accessible.
2. Turn off the engine.
3. Press the fuel fill door release on the inside of the driver's door. The fuel fill door opens.
4. Turn the fuel fill cap slowly to open. Place the fuel fill cap in the holder.
5. Insert the filler nozzle fully. When the tank is full, the fuel nozzle clicks off automatically.
6. Replace the fuel fill cap. Tighten it until you hear at least one click. Close the fuel fill door.



⚠ WARNING

Gasoline is highly flammable and explosive. You can be burned or seriously injured when handling fuel.

- Stop the engine, and keep heat, sparks, and flame away.
- Handle fuel only outdoors.
- Wipe up spills immediately.

HANDLING THE UNEXPECTED

Learn about what to do in critical or emergency situations.

Keyless Access Remote Battery Strength

If the battery life in your remote transmitter is weak, a message appears in the MID with information on how to start the engine.

1. Touch the back of the remote transmitter to the ENGINE START/STOP button while the indicator is flashing.
2. With the brake pedal pressed, press the ENGINE START/STOP button within 10 seconds.

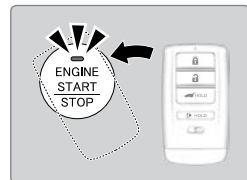

Jump Starting

Turn off the power to electric devices, such as audio and lights. Turn off the engine, then open the hood (see page 133).

1. Remove the engine compartment cover (see page 133).
2. Connect the first jumper cable to your vehicle's battery (+) terminal.
3. Connect the other end of the first jumper cable to the booster battery (+) terminal. Use a 12-volt booster battery only.
4. Connect the second jumper cable to the booster battery (-) terminal.
5. Connect the other end of the second jumper cable to the engine hanger as shown. Do not connect this jumper cable to any other part.
6. If your vehicle is connected to another vehicle, start the assisting vehicle's engine and increase its rpm slightly.
7. Attempt to start your vehicle's engine. If it turns over slowly, make sure that the jumper cables have good metal-to-metal contact.

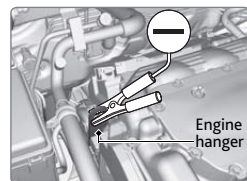
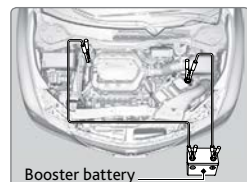
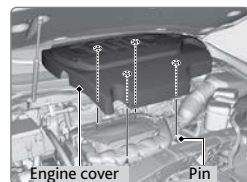

WARNING: Battery posts, terminals, and related accessories contain lead and lead compounds. **Wash your hands after handling.**

⚠️ WARNING

A battery can explode if you do not follow the correct procedure, seriously injuring anyone nearby.

Keep all sparks, open flames, and smoking materials away from the battery.

■ After the Engine Starts

Once your vehicle's engine has started, remove the jumper cables in the following order:

1. Disconnect the jumper cable from your vehicle's ground.
2. Disconnect the other end of the jumper cable from the booster battery (-) terminal.
3. Disconnect the jumper cable from your vehicle's battery (+) terminal.
4. Disconnect the other end of the jumper cable from the booster battery (+) terminal.
5. Have your vehicle inspected by a nearby service station or a dealer.

Emergency Engine Stop

The ENGINE START/STOP button may be used to stop the engine due to an emergency situation even while driving. If you must stop the engine, choose one of the following operations:

- Press and hold the ENGINE START/STOP button for two seconds, **OR**
- Firmly press the ENGINE START/STOP button two times.



The steering wheel will not lock. The power mode changes to ACCESSORY (unless the gear is in Park, in which case the power mode changes to VEHICLE OFF).

Because turning off the engine also disables the power assist the engine provides to the steering and braking systems, it will require significantly more physical effort and time to steer and slow the vehicle. Downshift gears and use both feet on the brake pedal, if necessary, to slow the vehicle and stop immediately in a safe place.

Do not press the button while driving unless it is absolutely necessary for the engine to be switched off.

Overheating

If the temperature gauge needle is at the H mark, the engine suddenly loses power, or steam or spray comes out from under the hood, your engine is overheating.

1. Immediately park the vehicle in a safe place. Turn off all accessories and turn on the hazard warning lights.



2. **If no steam or spray is present:** Keep the engine running and open the hood (see page 133).

If steam or spray is present: Turn off the engine and wait until it subsides. Then, open the hood.

3. Check that the cooling fan is operating and stop the engine once the temperature gauge needle goes down. If the cooling fan is not operating, immediately stop the engine.
4. Once the engine has cooled down, inspect the coolant level and check the cooling system components for leaks. If the coolant level in the reserve tank is low, add coolant until it reaches the MAX mark. If there is no coolant in the reserve tank, make sure the radiator is cool, then cover the radiator cap with a heavy cloth and open the cap. If necessary, add coolant up to the base of the filler neck, and put the cap back on.

Once the engine has cooled sufficiently, restart it and check the temperature gauge. If the temperature needle has gone down, resume driving. If it has not gone down, contact a dealer for repairs.

⚠️ WARNING

Steam and spray from an overheated engine can seriously scald you. Do not open the hood if steam is coming out.

⚠️ WARNING

Removing the radiator cap while the engine is hot can cause the coolant to spray out, seriously scalding you. Always let the engine and radiator cool down before removing the radiator cap.

NOTICE

Continuing to drive with the temperature gauge needle at the H mark may damage the engine.

Tire Pressure Monitoring System (TPMS)

Monitors the tire pressure while you are driving. Use the right selector wheel on the steering wheel to scroll to the tire pressure monitor to see pressure readings for each tire (see page 28).

If your vehicle's tire pressure becomes significantly low, the low tire pressure indicator appears with a message in the multi-information display.

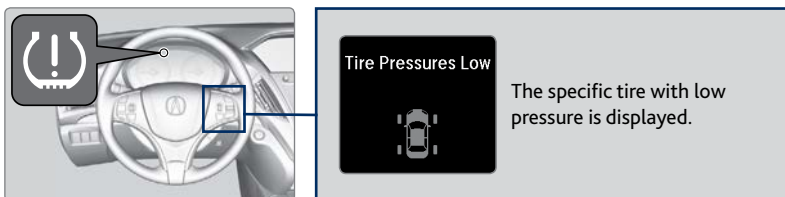

What to Do

Stop your vehicle in a safe place. Adjust the tire pressure to the level specified on a label on the driver's doorjamb.

Tire Fill Assist

Your vehicle gives you visual and audible alerts to help you adjust the tire pressure to its appropriate level when the vehicle is on.

While inflating: The system beeps and the exterior lights flash once every 5 seconds.

When the correct pressure is reached: The system beeps and the exterior lights flash continuously for 5 seconds. Stop filling the tire.

If you overinflate: The system beeps and the exterior lights flash twice every 3 seconds.

NOTICE

Driving on an extremely underinflated tire can cause it to overheat. An overheated tire can fail. Always inflate your tires to the specified pressure.

Tire Pressure Monitoring System (TPMS) - Required Federal Explanation

Each tire, including the spare (if provided), should be checked monthly when cold and inflated to the inflation pressure recommended by the vehicle manufacturer on the vehicle placard or tire inflation pressure label.

(If your vehicle has tires of a different size than the size indicated on the vehicle placard or tire inflation pressure label, you should determine the proper tire inflation pressure for those tires.)

As an added safety feature, your vehicle has been equipped with a tire pressure monitoring system (TPMS) that illuminates a low tire pressure telltale when one or more of your tires is significantly under-inflated.



Accordingly, when the low tire pressure telltale illuminates, you should stop and check your tires as soon as possible, and inflate them to the proper pressure.

Driving on a significantly under-inflated tire causes the tire to overheat and can lead to tire failure. Under-inflation also reduces fuel efficiency and tire tread life, and may affect the vehicle's handling and stopping ability.

Please note that the TPMS is not a substitute for proper tire maintenance, and it is the driver's responsibility to maintain correct tire pressure, even if under-inflation has not reached the level to trigger illumination of the TPMS low tire pressure telltale.

Your vehicle has also been equipped with a TPMS malfunction indicator to indicate when the system is not operating properly. The TPMS malfunction indicator is combined with the low tire pressure telltale. When the system detects a malfunction, the telltale will flash for approximately one minute and then remain continuously illuminated. This sequence will continue upon subsequent vehicle start-ups as long as the malfunction exists.

When the malfunction indicator is illuminated, the system may not be able to detect or signal low tire pressure as intended.

TPMS malfunctions may occur for a variety of reasons, including the installation of replacement or alternate tires or wheels on the vehicle that prevent the TPMS from functioning properly.

Always check the TPMS malfunction telltale after replacing one or more tires or wheels on your vehicle to ensure that the replacement or alternate tires and wheels allow the TPMS to continue to function properly.

Changing a Flat Tire

If a tire goes flat while driving, grasp the steering wheel firmly, and brake gradually to reduce speed. Stop in a safe place. Replace the flat tire with a compact spare tire.* Go to a dealer as soon as possible to have the full-size tire repaired or replaced.

■ Before Changing the Tire

1. Park the vehicle on firm, level, non-slippery surface.
2. Change the gear to Park (P), and apply the parking brake.
3. Turn on the hazard warning lights and turn the vehicle off.

■ Getting Ready to Change the Tire

1. Open the tailgate. Turn on the cargo lights located on the inside of the tailgate, if necessary (see page 36). Push the rear edge of the handle on the floor lid and open the lid.



2. Take out the cargo floor box.



3. Take the jack, wheel nut wrench, and jack handle bar out of the tool case.



4. Remove the cover on the cargo area lining to access the shaft for the spare tire hoist.

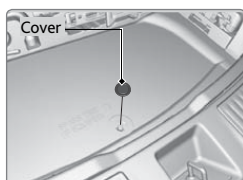

*if equipped

5. Put the wheel nut wrench with the jack handle bar on the hoist shaft. Turn the wrench to the left to lower the spare tire to the ground.

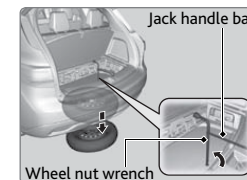

6. Keep turning the wheel nut wrench to create slack in the cable. Remove the bracket from the spare tire.

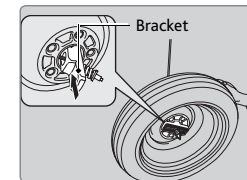

7. Place the compact spare tire wheel side up under the vehicle body, near the tire that needs to be replaced.



8. Loosen each wheel nut about one turn using the wheel nut wrench.



■ Setting Up the Jack

1. Place the jack under the jacking point closest to the tire to be changed.

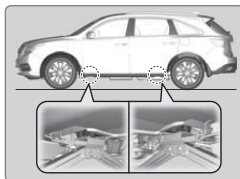

2. Turn the end bracket clockwise (as shown in the image) until the top of the jack contacts the jacking point. Make sure that the jacking point tab is resting in the jack notch.



3. Raise the vehicle, using the jack handle bar and the jack handle, until the tire is off the ground.

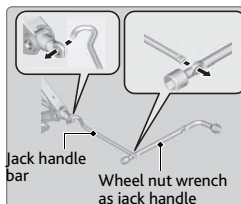

⚠ WARNING

The vehicle can easily roll off the jack, seriously injuring anyone underneath. Follow the directions for changing a tire exactly, and never get under the vehicle when it is supported only by the jack.

The following instructions must be followed to use the jack safely:

- Do not use the jack with people or luggage in the vehicle.
- Use the jack provided in your vehicle. Other jacks may not support the weight ("load") or fit the jacking point.
- Do not use while the engine is running.
- Use only where the ground is firm and level.
- Use only at the jacking points.
- Do not get in the vehicle while using the jack.
- Do not put anything on top of or underneath the jack.

NOTICE

Do not use the jack if it doesn't work properly. Call your dealer or a professional towing service.

■ Replacing the Flat Tire

1. Remove the wheel nuts and flat tire.
2. Mount the compact spare tire. Replace the wheel nuts, and lightly tighten them.
3. Lower the vehicle and remove the jack. Tighten the wheel nuts in the order indicated in the image. Go around, tightening the nuts, two to three times in this order. Do not over tighten the wheel nuts.

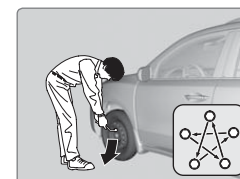

If you drive with the spare tire installed, the low tire pressure/TPMS indicator appears. The indicator stays on until a regular tire is installed.

■ Storing the Flat Tire

1. Remove the center cap and place the flat tire face up under the hoist.
2. Insert the hoist bracket into the center hole of the flat tire.
3. Turn the wheel nut wrench with the jack handle bar clockwise until the flat tire rests against the underbody of the vehicle and you hear the hoist click.
4. Securely store the jack and wheel nut wrench back in the tool case. Store the case in the cargo area.

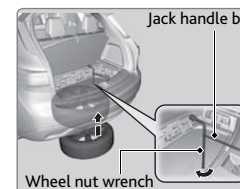
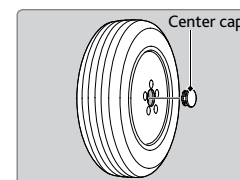

⚠ WARNING

Loose items can fly around the interior in a crash and can seriously injure the occupants. Store the wheel, jack, and tools securely before driving.

Tire Repair Kit*

If a tire has a small puncture, you can use the tire repair kit to temporarily repair it. The puncture must be smaller than 3/16-inch (4 mm) and not in the tire sidewall. Go to a dealer to have the full-size tire permanently repaired or replaced.

■ Before Repairing the Tire

1. Park the vehicle on firm, level, non-slippery surface.
2. Change the gear to Park (P), and apply the parking brake.
3. Turn on the hazard warning lights and turn the vehicle off.

■ Getting Ready to Repair the Tire

1. Pull the handle on the cargo area floor lid and open the lid.
2. Remove the cargo floor box.
3. Remove the kit from the case.
4. Place the kit face up on flat ground near the punctured tire and away from traffic. Do not place the kit on its side.
5. Follow the instructions in the kit to repair the tire.

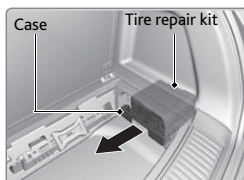

NOTICE

Do not use an unapproved puncture-repairing agent on a flat tire, as it can damage the tire pressure sensor.

*if equipped

Fuse Locations

If any electrical devices are not working, turn off the vehicle and check to see if any applicable fuse is blown. Fuse locations are shown on the fuse box cover. Locate the fuse by the fuse number and box cover number.

■ Driver's Side Interior Fuse Boxes

Type A

Located under the dashboard.

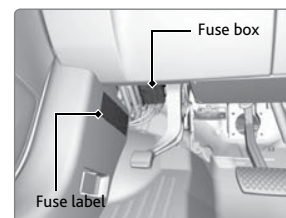

	Circuit Protected	Amps
1	AS Door Lock	10 A
2	RR AS Door Lock	7.5 A
3	DR Door Lock	7.5 A
4	FR AS Door Unlock	10 A
5	RR AS Door Unlock	7.5 A
6	DR Door Unlock	7.5 A
7	D/L Main	20 A
8	–	–
9	ETS TELE	20 A
10	IG1 RR	15 A
11	Meter* Shifter*	7.5 A
12	IG1 FR	20 A
13	ACC	7.5 A

	Circuit Protected	Amps
14	–	–
15	DR P/Seat (SLI)	20 A
16	S/R	20 A
17	RR DR P/W	20 A
18	Smart	10 A
19	FR DR P/W	20 A
20	–	–
21	Fuel Pump	20 A
22	IG1 AS	15 A
23	ABS/VSA* Smart*	7.5 A
24	ACG AS	7.5 A
25	STRLD*	7.5 A
26	IG2 HAC	7.5 A
27	DRL	(7.5 A)
28	ACC Key Lock	7.5 A
29	DR P/Seat (LUM)	7.5 A
30	INT Lights	7.5 A
31	ETS TILT	20 A
32	DR P/Seat (REC)	20 A
33	–	–
34	–	–

Type B*

Located under the Type A driver's side fuse box. Take off the cover to open.

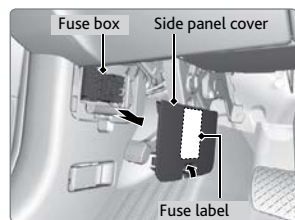

	Circuit Protected	Amps
1	VST 1	30 A
2	Horn	10 A
3	VST 2	30 A
4	-	-
5	-	-
6	-	-
7	-	-
8	-	-
9	Meter	10 A
10	RES*	7.5 A
11	MICU	7.5 A
12	EPS/VSA	7.5 A
13	Audio/TCU	7.5 A
14	Back Up	10 A
15	Audio/ANC	20 A

Passenger's Side Interior Fuse Box

Located on the lower side panel. Remove the cover to access.

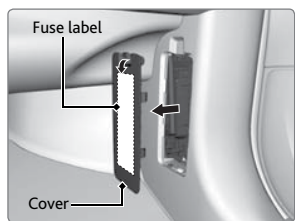

	Circuit Protected	Amps
1	EPTR*	(30 A)
2	RR AS P/W	20 A
3	ACM	20 A
4	FR DEF*	(15 A)
5	AVS Heated Seat	20 A
6	FR AS P/W	20 A
7	AS P/Seat (SLI)	20 A
8	AS P/Seat (REC)	20 A
9	AS P/Seat (LUM)	(7.5 A)

	Circuit Protected	Amps
10	Spare	5 A
11	Heated Steering *	(10 A)
12	-	-
13	-	-
14	RR ACC Socket	20 A
15	FR ACC Socket	20 A
16	-	-
17	-	-
18	AMP	30 A
19	SRS	10 A
20	AS ECU	7.5 A
21	Option	7.5 A
22	-	-
23	-	-
24	OPDS	7.5 A
25	ILLUMI (INT)	5 A
26	EPTL*	(30 A)
27	CTR ACC Socket	20 A
28	AC INVTR	(30 A)

*if equipped

Engine Compartment Fuse Boxes

Type A

Located near the brake fluid reservoir. Push the tabs to open the box.

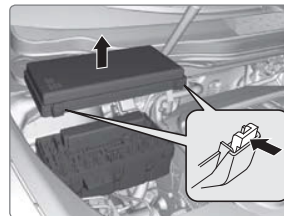

	Circuit Protected	Amps
1	STRLD ²	7.5 A
2	-	-
3	ACG FR	15 A
4	Washer	15 A
5	-	-
6	ECU FR	7.5 A
7	Starter ²	7.5 A
8	FI Sub	15 A
9	DBW	15 A
10	FI Main	15 A
11	IG Coil	15 A
12	DRL R	10 A

	Circuit Protected	Amps
13	DRL L	10 A
14	Injector	20 A
15	Radio ¹	20 A
16	Back Up	10 A
17	MG Clutch	7.5 A
18	FR Fog*	(20 A)
19	-	-
20	H/L HI R	7.5 A
21	-	-
22	Small ¹	10 A
23	Gear Selector	15 A
24	H/L HI L	7.5 A
25	-	-
26	H/L LO R	10 A
27	H/L LO L	10 A
28	Oil LVL	7.5 A
29	Main Fan	30 A
30	Sub Fan	30 A
31	Wiper Main	30 A

*1: Models without auto idle stop

*2: Models with auto idle stop

*if equipped

Type B

Located near the battery. Push the tabs to open the box.

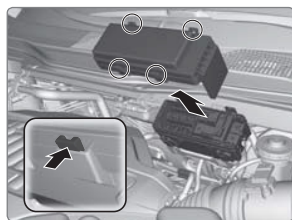

	Circuit Protected	Amps
1	Main Fuse	150 A
	VSA MTR	40 A
	VSA FSR	20 A
	Stop&Horn Hazard * Hazard *	30 A
2	RR Blower	30 A
	DC/DC 3 *	60 A
	RR F/B-2	60 A
	AS F/B-2	60 A
	EPS	60 A

	Circuit Protected	Amps
3	H/L Washer *	(30 A)
	IG1B Main	30 A
	R/B Main	60 A
	DR F/B-1	50 A
	AS F/B-1	50 A
	RR F/B-1	60 A
	IG1A Main	30 A
4	DR F/B-2	50 A
	FI Main	40 A
5	FR Blower	40 A
6	RR DEF	40 A
7	IG1 Main ST	30 A
8	Stop & Horn *	20 A
	Stop *	10 A
9	Hazard	15 A
10	BMS	7.5 A
11	Small LT *	7.5 A

■ Rear Fuse Box

Located on the left side of the cargo area. Remove the cover using a cloth-wrapped flat-tip screwdriver to access.

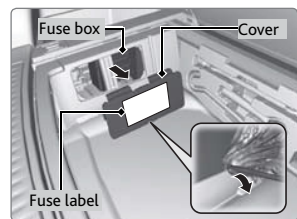

	Circuit Protected	Amps
1	PTG Closer	20 A
2	Trailer Small LT *	(20 A)
3	-	-
4	Fuel Lid	7.5 A

	Circuit Protected	Amps
5	Seat Slide	20 A
6	-	-
7	RR Heat Seat *	(20 A)
8	-	-
9	Trailer Charge *	(20 A)
10	Trailer Back LT *	(7.5 A)
11	Trailer Hazard *	(7.5 A)
12	Rear Wiper	10 A
13	Rear ECU	7.5 A
14	4WD	(20 A)
15	-	-
16	-	-
17	Trailer E-Brake *	(20 A)
18	PTG MTR	40 A

*if equipped

■ Inspecting and Changing Fuses

1. Turn off the vehicle, including headlights and all accessories.
2. Remove the fuse box cover.
3. Check all fuses inside the combined fuse case in the engine compartment. If any fuse is blown, use a Phillips-head screwdriver to remove the screws and replace the fuse with a new one. Reinstall the screws.
4. Inspect the small fuses in the engine compartment and the vehicle interior. If there is a burned out fuse, remove it with the fuse puller and replace it with a new one.

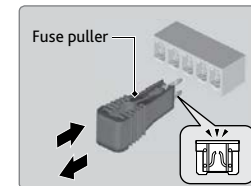
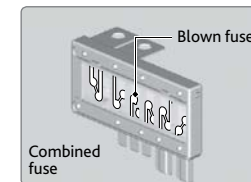

NOTICE

Replacing a fuse with one that has a higher rating greatly increases the chances of damaging the electrical system.

Emergency Towing

Call a professional towing service if you need to tow your vehicle.

All models

Flat bed equipment: The operator loads your vehicle on the back of a truck. **This is the best way to transport your vehicle.**

2WD models

Wheel lift equipment: The tow truck uses two pivoting arms that go under the front tires and lift them off the ground. The rear tires remain on the ground. **This is an acceptable way to tow your vehicle.**

NOTICE

Trying to lift or tow your vehicle by the bumpers will cause serious damage. The bumpers are not designed to support the vehicle's weight.

Improper towing such as towing behind a motorhome or other motor vehicle can damage the transmission.

MAINTENANCE

Learn about basic maintenance that you can perform on the vehicle yourself, as well as information about how to best maintain the vehicle.

Safety Precautions

Some of the most important safety precautions are listed below; however, we cannot warn you of every conceivable hazard that can arise in performing maintenance. Only you can decide whether or not you should perform a given task.

■ Maintenance Safety

- To reduce the possibility of fire or explosion, keep cigarettes, sparks, and flames away from the battery and all fuel-related parts.
- Never leave rags, towels, or other flammable objects under the hood.
- To clean parts, use a commercially available degreaser or parts cleaner, not gasoline.
- Wear eye protection and protective clothing when working with the battery or compressed air.
- Do not run the engine in confined spaces where carbon monoxide gas can accumulate.

■ Vehicle Safety

- The vehicle must be stationary, and parked on level ground with the parking brake set and the engine off.
- Be aware that hot parts can burn you.
- Be aware that moving parts can injure you.

⚠ WARNING

Improperly maintaining this vehicle or failing to correct a problem before driving can cause a crash in which you can be seriously hurt or killed. Always follow the inspection and maintenance recommendations according to the schedules in this guide.

⚠ WARNING

Failure to properly follow maintenance instructions and precautions can cause you to be seriously hurt or killed. Always follow the procedures and precautions in this guide.

Maintenance Minder™

When maintenance is due, the system message indicator comes on and the Maintenance Minder appears on the multi-information display every time you turn the vehicle on. Roll the right selector wheel to change displays.

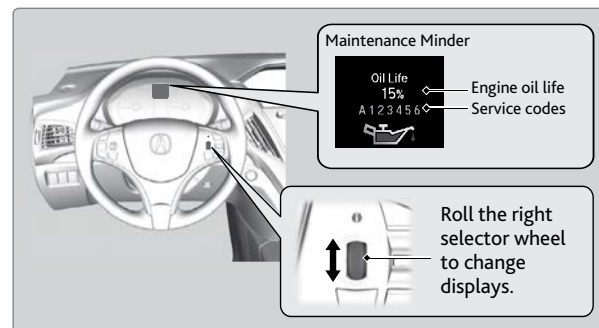

- Independent of the Maintenance Minder information, replace the brake fluid every 3 years.
- Inspect idle speed every 160,000 miles (256,000 km).
- Adjust the valves during services A, B, 1, 2, or 3 if they are noisy.

U.S. models

Maintenance, replacement, or repair of emissions control devices and systems may be done by any automotive repair establishment or individuals using parts that are certified to EPA standards.

According to state and federal regulations, failure to perform maintenance on the maintenance main items marked with # will not void your emissions warranties. However, all maintenance services should be performed in accordance with the intervals indicated by the multi-information display.

TABLE OF CONTENTS

VISUAL INDEX

SAFETY INFORMATION

INSTRUMENT PANEL

VEHICLE CONTROLS

AUDIO AND CONNECTIVITY

BLUETOOTH® HANDSFREELINK®

ACURALINK®

NAVIGATION

DRIVING

HANDLING THE UNEXPECTED

MAINTENANCE

SPECIFICATIONS

CLIENT INFORMATION

VOICE COMMAND INDEX

INDEX

■ Maintenance Minder Service Codes

These codes indicate what services are due on your vehicle.

CODE	Maintenance Main Items
A	Replace engine oil* ¹
B	Replace engine oil* ¹ and oil filter Inspect front and rear brakes Check parking brake adjustment Check expiration date for TRK bottle* Inspect tie rod ends, steering gearbox, and boots Inspect suspension components Inspect driveshaft boots Inspect brake hoses and lines (Including ABS/VSA) Inspect all fluid levels and condition of fluids Inspect exhaust system# Inspect fuel lines and connections#

*1: If the message Maintenance Due Now does not appear more than 12 months after the display is reset, change the engine oil every year.
#: See information on maintenance and emissions warranty.
*2: If you drive in dusty conditions, replace the air cleaner element every 15,000 miles (24,000 km).
*3: If you drive primarily in urban areas that have high concentrations of soot in the air from industry and diesel-powered vehicles, replace the dust and pollen filter every 15,000 miles (24,000 km).

CODE	Maintenance Sub Items
1	Rotate tires
2	Replace air cleaner element* ² Replace dust and pollen filter* ³ Inspect drive belt
3	Replace transfer-case fluid* and transmission fluid* ⁴
4	Replace spark plugs Replace timing belt and inspect water pump* ⁵ Inspect valve clearance
5	Replace engine coolant
6	Replace rear differential fluid* ⁶

*4: Driving in mountainous areas at very low vehicle speeds or trailer towing results in higher transmission temperature. This requires transmission fluid changes more frequently than recommended by the Maintenance Minder. If you regularly drive your vehicle under these conditions, have the transmission fluid changed at 30,000 miles (48,000 km).
*5: If you drive regularly in very high temperatures (over 110°F, 43°C), in very low temperatures (under -20°F, -29°C), replace every 60,000 miles/100,000 km.
*6: Driving in mountainous areas at very low vehicle speeds or trailer towing results in higher level of mechanical (Shear) stress to fluid. This requires differential fluid changes more frequently than recommended by the Maintenance Minder. If you regularly drive your vehicle under these conditions, have the differential fluid changed at 7,500 miles (12,000 km), then every 15,000 miles (24,000 km).

*if equipped

Under the Hood

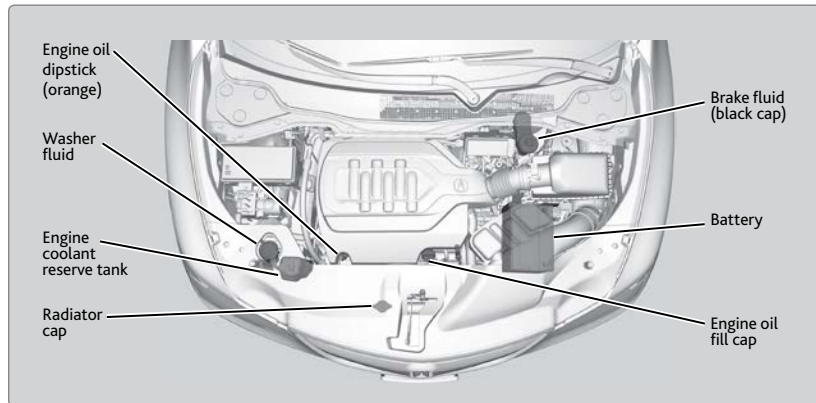

■ Opening the Hood

1. Park the vehicle on a level surface, and set the parking brake.
2. Pull the hood release handle under the lower left corner of the dashboard.
3. Push up the hood latch lever in the center of the hood to release the lock mechanism, and open the hood.
4. Lift the hood up about halfway. The hydraulic supports will continue to lift and hold it up.
When closing, lower the hood to approximately 12 inches (30 cm), then press down firmly with your hands.

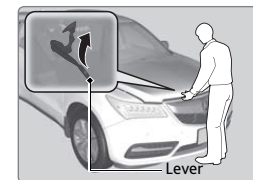
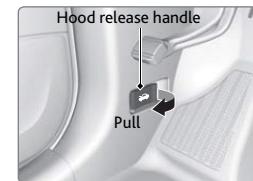

NOTICE

Do not open the hood when the wiper arms are raised. The hood will strike the wipers, and may damage either the hood or the wipers. Do not open the hood during auto idle stop operation.*

■ Engine Compartment Cover

Certain parts in the engine compartment are protected by a cover. You may need to remove the cover when you perform certain maintenance work.
Pull up on the engine cover, and remove it from the pins. Start on the passenger's side and lift the outermost edge of the cover. Move towards the driver side while applying uniform upward pressure.



*if equipped

TABLE OF CONTENTS

VISUAL INDEX

SAFETY INFORMATION

INSTRUMENT PANEL

VEHICLE CONTROLS

AUDIO AND CONNECTIVITY

BLUETOOTH® HANDSFREELINK®

ACURALINK®

NAVIGATION

DRIVING

HANDLING THE UNEXPECTED

MAINTENANCE

SPECIFICATIONS

CLIENT INFORMATION

VOICE COMMAND INDEX

INDEX

Engine Oil

Park the vehicle on level ground, and wait approximately three minutes after turning the engine off before you check the oil.

■ Checking the Oil

1. Remove the dipstick (orange loop).
2. Wipe the dipstick with a clean cloth or paper towel.
3. Insert the dipstick all the way back into its hole.
4. Remove the dipstick again, and check the level. It should be between the upper and lower marks. Add oil if necessary.

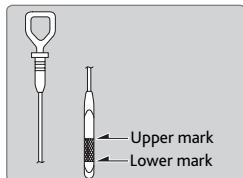
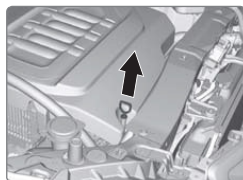

■ Recommended Engine Oil

- Genuine Acura Motor Oil
- Premium-grade 0W-20 detergent oil with an API Certification Seal on the container

This seal indicates the oil is energy conserving and that it meets the American Petroleum Institute's latest requirements.



Use Genuine Acura Motor Oil or another commercial engine oil of suitable viscosity for the ambient temperature as shown.

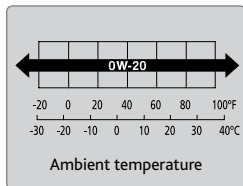

You may also use synthetic motor oil if it is labeled with the API Certification Seal and is of the specified viscosity grade.

■ Adding Oil

1. Unscrew and remove the engine oil fill cap.
2. Add oil slowly.
3. Reinstall the engine oil fill cap, and tighten it securely.
4. Wait for three minutes and recheck the engine oil dipstick.

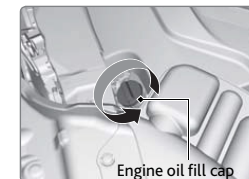

NOTICE

Do not fill the engine oil above the upper mark. Overfilling the engine oil can result in leaks and engine damage.

■ Resetting the Engine Oil Life

If you change or replace the vehicle's engine oil yourself, you must reset the engine oil life. Use the right selector wheel on the steering wheel to make selections in the MID.

1. Scroll to Maintenance Info and select it to display the oil life reset mode.
2. Select Reset. The service code disappears and the oil life returns to 100%.

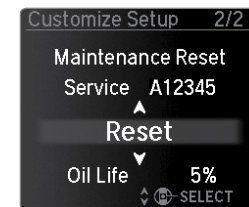

NOTICE

Failure to reset the engine oil life after a maintenance service results in the system showing incorrect maintenance intervals, which can lead to serious mechanical problems.

Engine Coolant

Park the vehicle on level ground. Check the reserve tank and the coolant level in the radiator. **We recommend Acura Long Life Antifreeze/Coolant Type 2.**

■ Checking the Reserve Tank

1. Check the amount of coolant in the reserve tank.
2. If the coolant level is below the MIN mark, add the specified coolant until it reaches the MAX mark.
3. Inspect the cooling system for leaks.

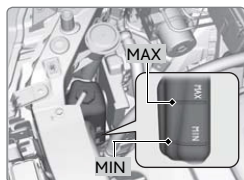

NOTICE

If temperatures consistently below -22°F (-30°C) are expected, the coolant mixture should be changed to a higher concentration. Consult a dealer for more information.

■ Adding Coolant

1. Make sure the engine and radiator are cool.
2. Remove the engine compartment cover (see page 133).
3. Turn the radiator cap counterclockwise and relieve any pressure in the coolant system. Do not push the cap down when turning.
4. Push down and turn the radiator cap counterclockwise to remove it.
5. The coolant level should be up to the base of the filler neck. Add coolant if it is low.
6. Put the radiator cap back on, and tighten it fully.
7. Pour coolant into the reserve tank until it reaches the MAX mark. Put the cap back on the reserve tank.

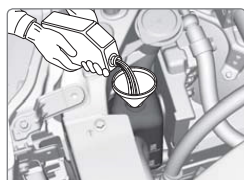
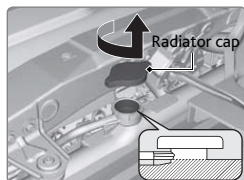

⚠️ WARNING

Removing the radiator cap while the engine is hot can cause the coolant to spray out, seriously scalding you.
Always let the engine and radiator cool down before removing the radiator cap.

NOTICE

Pour the fluid slowly and carefully so you do not spill any. Clean up any spills immediately; they can damage components in the engine compartment.

Window Washer Fluid

Add washer fluid as necessary (see page 133). Pour it carefully, and do not overflow the reservoir.



Washer Fluid Low



If the washer fluid is low, a message appears on the multi-information display.

NOTICE

Do not use engine antifreeze or a vinegar/water solution in the windshield washer reservoir. Antifreeze can damage your vehicle's paint. A vinegar/water solution can damage the windshield washer pump.

Checking the Battery

The battery condition is monitored by the sensor on the negative terminal. If there is a problem with the sensor, have your vehicle checked by a dealer. Check the battery terminals monthly for corrosion.

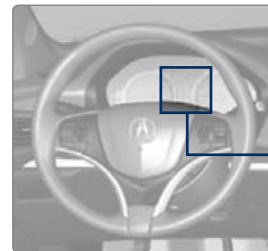

Charging System Problem



If there is a problem with the battery sensor, a message appears on the multi-information display.

For Jump starting, see page 115.

⚠️ WARNING

The battery gives off explosive hydrogen gas during normal operation. A spark or flame can cause the battery to explode with enough force to kill or seriously hurt you.
When conducting any battery maintenance, wear protective clothing and a face shield, or have a skilled technician do it.

WARNING: Battery posts, terminals, and related accessories contain lead and lead compounds. **Wash your hands after handling.**

Changing Wiper Blades

If the wiper blades leave streaks across the windshield, try cleaning them first with a paper towel or soft cloth and wiper fluid. If the wiper blade rubber has deteriorated, you should change the wiper blades.

■ Front Wiper Blades

1. Lift the driver side wiper arm first, then the passenger side.
2. Place a cloth on the edge of the lock tab. Push the lock tab up with a flat-tip screwdriver.
3. Slide the blade from the wiper arm.
4. Slide the wiper blade out from its holder by pulling the tabbed end out.
5. Remove the retainers from the rubber blade that has been removed, and mount to a new rubber blade. Correctly align the rubber protrusion and the retainer grooves.
6. Slide the new wiper blade onto the holder from the bottom end. The tab on the holder should fit in the indent of the wiper blade.
7. Slide the wiper blade onto the wiper arm, then push down the lock tab.
8. Lower the passenger side wiper arm first, then the driver side.

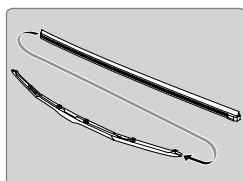
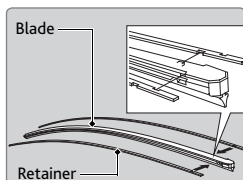
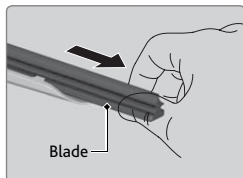
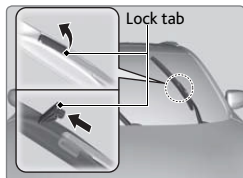
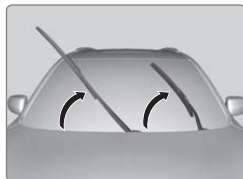

NOTICE

Avoid dropping the wiper arm, as it may damage the windshield.

■ Rear Wiper Blade

1. Raise the wiper arm off the window.
2. Slide the wiper blade out from the end with the indent.
3. Remove the retainers from the wiper blade and mount to a new rubber blade.
4. Slide the wiper blade onto the holder. Make sure it is engaged correctly, then install the wiper blade assembly onto the wiper arm.

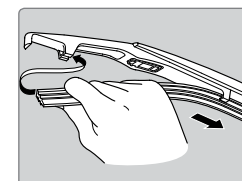
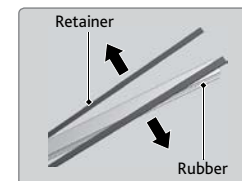
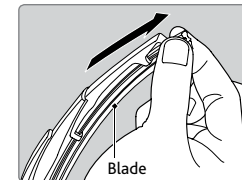

Tire Information

To safely operate your vehicle, your tires must be of the proper type and size, in good condition with adequate tread, and properly inflated.

Inflation Guidelines

- Properly inflated tires provide the best combination of handling, tread life, and comfort. Refer to the driver's doorjamb label or the specifications (see page 147) for the specified pressure.
- Underinflated tires wear unevenly, adversely affect handling and fuel economy, and are more likely to fail from overheating.
- Overinflated tires make your vehicle ride harshly, are more prone to road hazards, and wear unevenly.
- Every day before you drive, look at each of the tires. If one looks lower than the others, check the pressure with a tire gauge.
- Measure the air pressure when tires are cold. This means the vehicle has been parked for at least 3 hours, or driven less than 1 mile (1.6 km). If necessary, add or release air until the specified pressure is reached. If checked when hot, tire pressure can be as much as 4-6 psi (30-40 kPa, 0.3-0.5 kgf/cm²) higher than checked when cold.
- At least once a month or before long trips, use a gauge to measure the pressure in all tires, including the spare. Even tires in good condition can lose 1-2 psi (10-20 kPa, 0.1-0.2 kgf/cm²) per month.

Inspection Guidelines

Every time you inflate the tires, check for the following:

- Any damage to tires, including bumps, bulges, cuts, splits, or cracks in the side or tread. Remove any foreign objects and inspect for air leaks. Replace tires if you see fabric or cord.
- Uneven or excessive tread wear. Have a dealer check the wheel alignment.
- Cracks or other damage around the valve stems.

Wear Indicators

The groove where the wear indicator is located is 1/16 inch (1.6 mm) shallower than elsewhere on the tire. If the tread has worn so low that the indicator is exposed, replace the tire. **Worn out tires have poor traction on wet roads.**

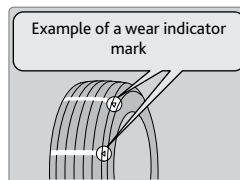

⚠ WARNING

Using tires that are excessively worn or improperly inflated can cause a crash in which you can be seriously hurt or killed. Follow all instructions in this owner's guide regarding tire inflation and maintenance.

Tire and Loading Information Label

The label attached to the driver's doorjamb provides necessary tire and loading information.

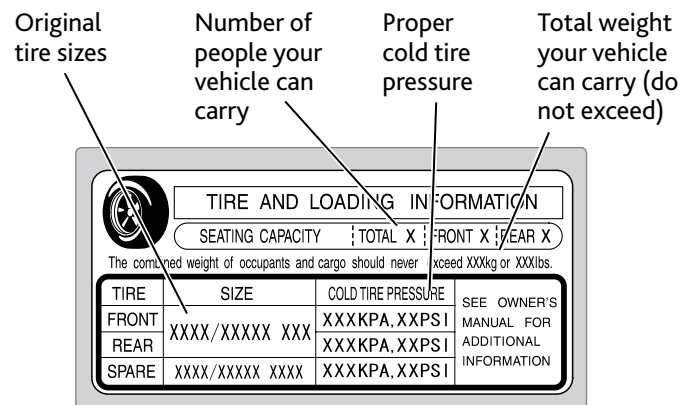

Tire and Wheel Replacement

Replace your tires with radials of the same size, load range, speed rating, and maximum cold tire pressure rating (as shown on the tire's sidewall). Using tires of a different size or construction can cause certain vehicle systems to work incorrectly. It is best to replace all four tires at the same time. If that isn't possible, replace the front or rear tires in pairs.

If you change or replace a wheel, make sure that the wheel's specifications match those of the original wheels. Only use TPMS-specified wheels approved for your vehicle.

⚠ WARNING

Installing improper tires on your vehicle can affect handling and stability. This can cause a crash in which you can be seriously hurt or killed. Always use the size and type of tires recommended in the Owner's Manual.

■ **Tire Service Life**

The life of your tires is dependent on many factors, including driving habits, road conditions, vehicle loading, inflation pressure, maintenance history, speed, and environmental conditions (even when the tires are not in use).

In addition to regular inspections and inflation pressure maintenance, it is recommended that you have annual inspections performed once the tires reach five years old. All tires, including the spare, should be removed from service after 10 years from the date of manufacture, regardless of their condition or state of wear.

■ **Winter Tires**

If driving on snowy or frozen roads, mount all season tires marked "M+S", snow tires, or tire chains; reduce speed; and maintain sufficient distance between vehicles when driving. For winter tires, select the size and load ranges that are the same as the original tires, and mount them to all four wheels.

■ **Tire Chains**

Install tire chains on the front tires only. Because your vehicle has limited tire clearance, we strongly recommend using the following chains: **Cable type: SCC Cable Chain ZT735**. Mount chains as tightly as you can, and make sure that they do not touch the brake lines or suspension.

NOTICE

Traction devices that are the wrong size or improperly installed can damage your vehicle's brake lines, suspension, body, and wheels. Stop driving if they are hitting any part of the vehicle.

⚠ WARNING

Using the wrong chains, or not properly installing chains, can damage the brake lines and cause a crash in which you can be seriously injured or killed. Follow all instructions in this guide regarding the selection and use of tire chains.

Tire Labeling

The tires that came on your vehicle have a number of markings. Those you should be aware of are described below.

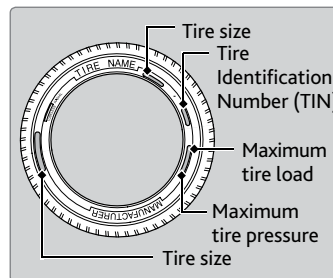

Here is an example of what each marking means:

215/70R16 100S

- 215: tire width in millimeters
- 70: aspect ratio (tire section height as a percentage of its width)
- R: tire construction code (radial)
- 16: rim diameter in inches
- 100: load index (code indicating maximum load tire can carry)
- S: speed symbol (code indicating maximum speed rating)

■ **Tire Identification Number (TIN)**

The tire identification number (TIN) is a group of numbers and letters that look like the example shown. TIN is located on the sidewall of the tire.

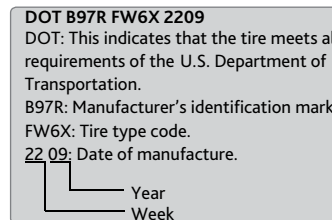

■ **Glossary of Tire Terminology**

Cold Tire Pressure – The tire air pressure when the vehicle has been parked for at least three hours or driven less than 1 mile (1.6 km).

Load Rating – The maximum load that a tire is rated to carry for a given inflation pressure.

Maximum Inflation Pressure – The maximum tire air pressure that the tire can hold.

Maximum Load Rating – The load rating for a tire at the maximum permissible inflation pressure for that tire.

Recommended Inflation Pressure – The cold tire inflation pressure recommended by the manufacturer.

Treadwear Indicators (TWI) – The projections within the principal grooves designed to give a visual indication of the degrees of wear of the tread.

TABLE OF CONTENTS

VISUAL INDEX

SAFETY INFORMATION

INSTRUMENT PANEL

VEHICLE CONTROLS

AUDIO AND CONNECTIVITY

BLUETOOTH® HANDSFREELINK®

ACURALINK®

NAVIGATION

DRIVING

HANDLING THE UNEXPECTED

MAINTENANCE

SPECIFICATIONS

CLIENT INFORMATION

VOICE COMMAND INDEX

INDEX

DOT Tire Quality Grading

The tires on your vehicle meet all U.S. Federal Safety Requirements. All tires are also graded for treadwear, traction, and temperature performance according to Department of Transportation (DOT) standards. The following explains these gradings.

■ Uniform Tire Quality Grading

Quality grades can be found where applicable on the tire sidewall between tread shoulder and maximum section width.

For example:

Treadwear 200
Traction AA
Temperature A

All passenger car tires must conform to Federal Safety Requirements in addition to these grades.

■ Treadwear

The treadwear grade is a comparative rating based on the wear rate of the tire when tested under controlled conditions on a specified government test course. For example, a tire graded 150 would wear one and one-half (1 1/2) times as well on the government course as a tire graded 100. The relative performance of tires depends upon the actual conditions of their use, however, and may depart significantly from the norm due to variations in driving habits, service practices, and differences in road characteristics and climate.

■ Traction

The traction grades, from highest to lowest, are AA, A, B, and C. Those grades represent the tire's ability to stop on wet pavement as measured under controlled conditions on specified government test surfaces of asphalt and concrete. A tire marked C may have poor traction performance.

WARNING: The traction grade assigned to this tire is based on straight-ahead braking traction tests, and does not include acceleration, cornering, hydroplaning, or peak traction characteristics.

■ Temperature

The temperature grades are A (the highest), B, and C, representing the tire's resistance to the generation of heat and its ability to dissipate heat when tested under controlled conditions on a specified indoor laboratory test wheel. Sustained high temperature can cause the material of the tire to degenerate and reduce tire life, and excessive temperature can lead to sudden tire failure. The grade C corresponds to a level of performance which all passenger car tires must meet under the Federal Motor Vehicle Safety Standard No. 109. Grades B and A represent higher levels of performance on the laboratory test wheel than the minimum required by law.

WARNING: The temperature grade for this tire is established for a tire that is properly inflated and not overloaded. Excessive speed, underinflation, or excessive loading, either separately or in combination, can cause heat buildup and possible tire failure.

Testing of Readiness Codes

Your vehicle has “Readiness Codes” as part of the onboard self-diagnostic system. Some states refer to these codes as a test to see if your vehicle’s emissions components are working properly. The codes may not be read if you go through the emissions testing just after the battery has gone dead or been disconnected.

To check if they are set, set the power mode to ON without starting the engine. The malfunction indicator lamp will come on for several seconds. If it goes off, the readiness codes are set. If it blinks five times, the readiness codes are not set.

If you are required to have your vehicle emissions tested before the readiness codes are set, prepare the vehicle for retesting by doing the following:

1. Fill the gas tank to approximately 3/4 full.
2. Park the vehicle and leave the engine off for 6 hours or more.
3. Make sure the ambient temperature is between 40°F and 95°F (4°C and 35°C).
4. Start the engine without touching the accelerator pedal, and let it idle for 20 seconds.
5. Keep the vehicle in Park (P). Increase the engine speed to 2,000 rpm, and hold it there for about 3 minutes.
6. Let the engine idle with your foot off the accelerator for 20 seconds.
7. Select a nearby, lightly traveled major highway where you can maintain a speed of 50 to 60 mph (80 to 97 km/h) for at least 20 minutes. Drive on the highway with the vehicle in Drive. Do not use cruise control. When traffic allows, drive for 90 seconds without using the accelerator pedal. (Vehicle speed may vary slightly; this is OK.) If you cannot do this for a continuous 90 seconds because of traffic conditions, drive for at least 30 seconds, then repeat two more times (for a total of 90 seconds).
8. Drive in city/suburban traffic for at least 10 minutes. When traffic conditions allow, let the vehicle coast for several seconds without using the accelerator pedal or the brake pedal.
9. Park the vehicle and leave the engine off for 30 minutes.

The readiness codes are erased when the battery is disconnected, and set again only after several days of driving under a variety of conditions.

If an emissions testing facility determines that the readiness codes are not set, you may be requested to return at a later date to complete the test, or see your dealer.

SPECIFICATIONS

Vehicle

Model	Acura MDX	
No. of Passengers:		
Front		2
Rear	2nd Row	3
	3rd Row	2
Total		7
Weights:		
Gross Vehicle Weight Rating	U.S.:	5,368 lbs (2,435 kg ¹)
	Canada:	5,677 lbs (2,575 kg ²)
		2,575 kg
Gross Axle Weight Rating (Front)	U.S.:	2,811 lbs (1,275 kg ¹)
	Canada:	2,910 lbs (1,320 kg ²)
		1,320 kg
Gross Axle Weight Rating (Rear)	U.S.:	2,734 lbs (1,240 kg ¹)
	Canada:	2,965 lbs (1,345 kg ²)
		1,345 kg
Gross Combined Weight Rating	U.S.:	8,036 lbs (3,645 kg ¹)
	Canada:	9,833 lbs (4,460 kg ²)
		4,460 kg
Air Conditioning:		
Refrigerant Type	HFC-134a (R-134a)	
Charge Quantity	23.8 – 25.6 oz (675 – 725 g)	
Lubricant Type	PAG RL897	
*1: 2WD models		
*2: AWD models		

Fluids

Engine Oil		
Recommended	<ul style="list-style-type: none"> • Genuine Acura Motor Oil 0W-20 • API Premium-grade 0W-20 detergent oil 	
	Change	5.4 US qt (5.1 ℓ)
Capacity	Change including filter	5.7 US qt (5.4 ℓ)
Engine Coolant		
Specified	Acura Long Life Antifreeze/Coolant Type 2	
Ratio	50/50 with distilled water	
Capacity	1.93 US gal (7.3 ℓ)	
	(change including the remaining 0.19 US gal (0.72 ℓ) in the reserve tank)	
Brake Fluid		
Specified	Acura Heavy Duty Brake Fluid DOT 3	
Automatic Transmission Fluid		
Specified	Acura Automatic Transmission Fluid ATF-TYPE 3.1 or higher	
Capacity	Change	3.5 US qt (3.3 ℓ)
Rear Differential Fluid *		
Specified	Acura DPSF-II	
Capacity	Change	1.92 US qt (1.82 ℓ)
Transfer Assembly Fluid *		
Specified	Acura Hypoid Gear Oil HGO-1	
	• Hypoid gear oil SAE 75W-85 or SAE 90 (API grade GL4 or GL5)	
Capacity	Change	0.45 US qt (0.43 ℓ)
Washer Fluid		
Tank Capacity	U.S.: 4 US qt (3.8 ℓ)	
	Canada: 5.6 US qt (5.3 ℓ)	

Tires

Regular	Size	245/60R18 105H ^{*1}
		245/55R19 103H ^{*2}
Compact Spare *	Pressure psi (kPa [kgf/cm ²])	35 (240 [2.4])
	Size	T165/80D17 104M
Wheel Size	Regular	18 x 8 ^{*1}
		19 x 8 ^{*2}
	Compact Spare [*]	17 x 4T

*1: Model with 18 inch wheel
*2: Model with 19 inch wheel

Engine and Fuel

Engine		
Displacement	211.8 cu-in (3,471 cm ³)	
Spark Plugs	NGK DILZKR7B11G	
Fuel		
Type	Unleaded premium gasoline, Pump octane number of 91 or higher	
Fuel Tank Capacity	19.5 US gal (73.8 ℓ)	

Light Bulbs

Headlights (High/Low Beam)	LED
Fog Lights *	LED
Front Turn Signal/Side Marker/Parking Lights	28/8 W (Amber)
Daytime Running Lights	LED
Side Turn Signal Lights (on Door Mirrors)	LED
Brake Lights	21 W
Rear Side Marker Lights	LED
Taillights	LED
Back-Up Lights	21 W
Rear Turn Signal Lights	21 W
High-Mount Brake Light	LED
Rear License Plate Light	LED
Puddle Lights *	LED
Interior Lights	
Front, Second Row and Third Row Lights	LED
Front and Rear Ambient Lights	LED
Vanity Mirror Lights	1.4 W
Door Courtesy Lights	3.4 W
Door Inner Handle Lights	LED
Console Compartment Light	1.4 W
Glove Box Light	1.4 W
Foot Lights	5 W
Cargo Area Lights	5 W

*if equipped

CLIENT INFORMATION

Learn about information specific to you as an Acura client and how to get help.

Frequently Asked Questions/Troubleshooting

Below are some frequently asked questions and troubleshooting items that you may have about the vehicle.

Q: *How do I set the vehicle clock?*

A: For vehicles without navigation, see page 51. For vehicles with navigation, the time is automatically set using GPS signals.

Q: *Why doesn't the vehicle start when I press the ENGINE START/STOP button?*

A: The brake pedal must be pressed to start the engine.

Q: *What is the AUTO setting on my headlight lever?*

A: When in the AUTO position, the vehicle's exterior lights will automatically turn on or off depending on the ambient lighting.

Q: *Why won't the driver's door unlock when I grab the door handle, even though the keyless access remote is within range?*

A: If you pull the handle too quickly, the system may not have time to confirm the door is unlocked. Wait to hear a beep to confirm the door is unlocked. If you are wearing gloves, the system may be slow to respond.

Q: *After my battery was disconnected or went dead, the audio system is asking for a code. Where do I find this?*

A: In most cases, you do not need to enter a code. Turn on the vehicle and the audio system, and press and hold the power button until the system reactivates.

Q: *Why can't I operate Pandora through the audio system?*

A: Audio may be streaming through *Bluetooth*® Audio. Make sure Pandora mode is selected and the phone cable is properly connected to the USB adapter. Some phones may prompt you to "Allow" a connection.

Q: *Is my phone compatible with Bluetooth features?*

A: Visit www.acura.com/handsfreelink (U.S) or www.handsfreelink.ca (Canada) to check phone compatibility for *Bluetooth*® Audio, *Bluetooth*® HandsFreeLink®, and SMS text messaging.

Q: *Every time I press the Talk button, the system gives me voice prompts. Can I turn these off?**

A: Press SETTINGS. Use the interface dial to select System Settings then Voice Rec. For the Voice Prompt option, select Off.

**if equipped*

Q: *Why can't I select an item using the interface dial?**

A: To prevent driver distraction, certain items are limited are inoperable while the vehicle is moving. Use voice commands or pull over to select the items.

Q: *Where can I find the vehicle identification number (VIN)?*

A: Check the label on the driver's doorjamb.

Contact Us

Acura dealer personnel are trained professionals. They should be able to answer all your questions. If you encounter a problem that your dealership does not solve to your satisfaction, please discuss it with the dealership's service manager or general manager. If you are dissatisfied with the decision made by the dealership's management, contact Acura Client Relations/Services.

U.S. Owners:

American Honda Motor Co., Inc.
Acura Client Relations
1919 Torrance Blvd.
Mail Stop 500-2N-7E
Torrance, CA 90501-2746
Tel: (800) 382-2238

In Puerto Rico and the U.S. Virgin Islands:

Bella International
P.O. Box 190816
San Juan, PR 00919-0816
Tel: (787) 620-7546

Canadian Owners:

Honda Canada, Inc.
Acura Client Services
180 Honda Blvd.
Markham, ON
L6C 0H9
Tel: (888)-922-8729
Fax: (877)-939-0909
E-Mail: acura_cr@ch.honda.com

When you call or write, please give us the following information:

- Vehicle Identification Number
- Date of purchase
- Odometer reading of your vehicle
- Your name, address, and telephone number
- A detailed description of the problem
- Name of the dealer who sold the vehicle to you

**if equipped*

Acura Total Luxury Care Roadside Assistance

Your Acura TLC Roadside Assistance representative is here to help you 24 hours a day, 7 days a week by calling (800) 594-8500 (U.S.) or (800) 565-7587 (Canada). Under your 4-year/50,000-mile (80,000-km) warranty, the following benefits are available:

- Towing services — full cost of towing to the closest Acura dealer
- Roadside assistance — jump starting, fuel delivery, lockout, and flat tire
- Trip planning — detailed trip routing, emergency services, and more

Warranty Coverages

Below is a brief summary of the warranties covering your new vehicle.

New Vehicle Limited Warranty: Covers your new vehicle, except for the emissions control system and accessories, against defects in materials and workmanship.

Emissions Control Systems Defects Warranty and Emissions Performance Warranty: Covers your vehicle's emissions control systems. Time, mileage, and coverage are conditional.

Seat Belt Limited Warranty: Covers seat belts that fail to function properly.

Rust Perforation Limited Warranty: Covers all exterior body panels that rust through from the inside.

Accessory Limited Warranty: Covers Acura accessories.

Replacement Parts Limited Warranty: Covers all Acura replacement parts against defects in materials and workmanship.

Replacement Battery Limited Warranty: Provides prorated coverage for a replacement battery purchased from an Acura dealer.

Replacement Muffler Lifetime Limited Warranty: Covers a replacement muffler for the duration of the ownership.

Restrictions and exclusions apply to all these warranties. See the Owner Information CD or visit owners.acura.com (U.S.) or myacura.ca (Canada) for complete descriptions of each warranty, including time, mileage, and other conditional limitations.

Your vehicle's original tires are covered by their manufacturer. Tire warranty information can be found on the Owner Information CD or at owners.acura.com (U.S.) or myacura.ca (Canada).

VOICE COMMAND INDEX

Learn about all available voice commands to help you operate the vehicle.

To view a list of available commands in the vehicle, press the INFO button and use the interface dial to select Voice Info. Select a category to hear the commands read aloud.

■ Voice Portal Commands

When you press the Talk button, the Voice Portal screen appears. Say one of the options, and follow the system prompts.

- Phone call
- Music search
- Voice help
- Navigation
- Audio
- Climate control
- What is today's date?
- What time is it?
- Call/dial (number)
- Call/dial (contact name)

■ Navigation Commands

When you press the Talk button and say "Navigation," you can say one of the options below. Follow the system prompts.

- Address (U.S. only)
- Place name (U.S. only)
- Find nearest POI category
- Go home
- Previous destination
- Address book
- Place phone number

■ Climate Control Commands

When you press the Talk button and say "Climate control," you can say one of the options below. Follow the system prompts.

- Climate control automatic
- Climate control on*
- Climate control off*
- Air conditioner on*
- Air conditioner off*
- Defrost on*
- Defrost off*
- Fan speed up
- Fan speed down
- Fan speed # (#: 1 to 7)
- Temperature # (#: 57 to 87°F, 18 to 32°C) degrees
- Temperature up
- Temperature down
- Temperature max heat
- Temperature max cool
- Vent
- Dash and floor
- Floor vents
- Floor and defrost

■ Phone Commands

When you press the Talk button and say "Phone call," you can say one of the options below. Follow the system prompts.

- Call/dial (contact name)
- Dial by number
- Redial
- Call history

*These commands toggle the function on and off, so the command may not match your intended action.

Audio Commands

When you press the Talk button and say “Audio,” you can say one of the options below. Follow the system prompts. Volume levels cannot be controlled using voice commands.

FM/AM Radio Commands

- Audio on*
- Audio off*
- FM
- AM
- Radio tune to # FM (#: frequency, e.g., 95.5)
- Radio tune to # AM (#: frequency, e.g., 1020)
- Radio FM preset # (#: 1 to 12)
- Radio AM preset # (#: 1 to 6)

Hard Disc Drive (HDD) Commands

- HDD
- HDD play
- HDD play track # (#: 1-30)

iPod® Commands

- iPod
- iPod play
- iPod play track # (#: 1-30)

Bluetooth® Audio Commands

Commands may not work on some phones or devices.

- *Bluetooth* audio
- *Bluetooth* audio play

Song By Voice™ Commands

Available for tracks stored on the HDD or iPod®.

- Music search
- What/Who am I listening to?
- Who is this?
- What’s playing?
- Who’s playing?
- What album is this?
- Play artist <Name>
- Play album <Name>
- Play song <Name>

SiriusXM® Radio Commands

- XM
- XM channel # (#: 0 to 255)
- XM preset # (#: 1 to 12)

Disc Commands

- Disc
- Disc play
- Disc play track # (#: 1 to 30)

USB Commands

- USB
- USB play
- USB play track # (#: 1 to 30)

Pandora® Commands

- Pandora
- Pandora play

Aha Radio™ Commands

- Aha
- Aha radio play

**These commands toggle the function on and off, so the command may not match your intended action.*

INDEX

ABS indicator.....	25	Automatic Rain-Sensing Wipers.....	38
ACC indicator.....	25, 27	Auto park mode.....	94
Accessory Power Socket.....	53	AUX Commands.....	154
AC Power Outlet.....	52	Auxiliary Input Jack.....	52
AcuraLink®.....	75	Battery.....	137
AcuraLink featuring Aha™.....	62	Blind Spot Information.....	25, 27, 108
AcuraLink Real-Time Traffic™.....	83	<i>Bluetooth</i> ® Audio.....	60
Acura Total Luxury Care Roadside Assistance.....	150	<i>Bluetooth</i> ® Audio Commands.....	152
Adaptive Cruise Control (ACC) with Low Speed Follow.....	100	<i>Bluetooth</i> ® HandsFreeLink®.....	67
Address.....	80	Call History.....	72
Aha™ Radio.....	62	Dialing a Number.....	70
Aha™ Radio Commands.....	152	Displays and Controls.....	67
Airbags.....	9	E-Mail.....	73
Advanced Airbags.....	9	Hang-Up/Back button.....	67
Airbag Care.....	14	Interface dial.....	67
Airbag System Components.....	13	Making a Call.....	70
Airbag System Indicators.....	11	Pairing a Phone.....	69
Driver’s Knee Airbag.....	9	Phonebook.....	71
Front Airbags (SRS).....	9	Pick-Up button.....	67
Side Airbags.....	10	Siri™ Eyes Free.....	74
Side Curtain Airbags.....	10	Speed Dial.....	71, 72
Anti-Lock Brake System (ABS).....	25, 98	Talk button.....	67
ASSIST button.....	76	Talk Button Tips.....	68
AUDIO button.....	54	Text Messaging.....	73
Audio Commands.....	152	Brake Assist System.....	98
Audio Operation.....	52	Brake system indicator.....	24, 25
Accessory Power Socket.....	53	Braking.....	98
AC Power Outlet.....	52	Brightness Control.....	35
AcuraLink featuring Aha™.....	62	Call History.....	72
Auxiliary Input Jack.....	52	Carbon Monoxide Gas.....	4
<i>Bluetooth</i> ® Audio.....	60	Cargo lights.....	36
Compact Disc.....	57	Car wash mode.....	95
FM/AM Radio.....	55	Change a Setting.....	51
Hard Disc Drive (HDD) Audio.....	58	Changing a Flat Tire.....	120
HDMI.....	64	Changing Fuses.....	129
Interface dial.....	54	Charging system.....	24
iPod®.....	59	Child Safety.....	15
MENU button.....	54	Childproof Door Locks.....	32
On-Demand Multi-Use Display (ODMD).....	54	Child Seat.....	17
Pandora®.....	61	Adding Security with a Tether.....	20
Rear Entertainment System.....	63	Installing a Child Seat.....	19
SiriusXM® Radio.....	56	LATCH-Compatible Child Seat.....	18
Sound.....	53	Selecting a Child Seat.....	17
SOURCE button.....	53	Client Information.....	148
Steering Wheel Controls.....	53	Climate Control Commands.....	151
USB Flash Drive.....	57	Climate Control System.....	47
USB Port.....	52	Clock.....	51
Auto idle stop.....	25, 27, 96	Collision Mitigation Braking System™ (CMBS™).....	25, 27, 103
Automatic Dimming Rearview Mirror.....	42	Compact Disc.....	57
		Compact Disc Commands.....	152
		Condition Indicators.....	26

TABLE OF CONTENTS
VISUAL INDEX
SAFETY INFORMATION
INSTRUMENT PANEL
VEHICLE CONTROLS
AUDIO AND CONNECTIVITY
BLUETOOTH® HANDSFREELINK®
ACURALINK®

NAVIGATION
DRIVING
HANDLING THE UNEXPECTED
MAINTENANCE
SPECIFICATIONS
CLIENT INFORMATION
VOICE COMMAND INDEX
INDEX

TABLE OF CONTENTS

VISUAL INDEX

SAFETY INFORMATION

INSTRUMENT PANEL

VEHICLE CONTROLS

AUDIO AND CONNECTIVITY

BLUETOOTH® HANDSFREELINK®

ACURALINK®

Contact Us 149

Cross Traffic Monitor 111

Cruise Control 27, 99

Customized Features 51

Dashboard and Ceiling Controls 2

Destination 80

Detour 83

Dialing a Number 70

Door Mirrors 42

Door Operation 30, 32

DOT Tire Quality Grading 144

Driver's Knee Airbag 9

Driving 84

 Adaptive Cruise Control (ACC) with Low Speed Follow 100

 Auto Idle Stop 96

 Blind Spot Information (BSI) 108

 Braking 98

 Collision Mitigation Braking System™ (CMBS™) 103

 Cruise Control 99

 ENGINE START/STOP button 93

 Forward Collision Warning (FCW) with Pedestrian Detection 102

 Integrated Dynamics System (IDS) 97

 Lane Departure Warning (LDW) 105

 Lane Keeping Assist System (LKAS) 106

 Maximum Load Limit 86

 Multi-View Rear Camera 110

 Paddle shifters 95

 Parking Sensor System 109

 Refueling 114

 Remote Engine Start 92

 Road Departure Mitigation (RDM) 107

 Sequential Mode 95

 Shifting 94

 Starting the Engine 93

 Surround View Camera 112

 Towing a Trailer 88

 Driving Position Memory System 43

 DVD 63

 Electric Power Steering 25

 Electronic Gear Selector 94

 Electronic Stability Control 97

 E-Mail 73

 Emergency Assistance 76

 Emergency Engine Stop 116

 Emergency Towing 129

 Engine and Fuel 147

 Engine Compartment Cover 133

 Engine Coolant 136

 ENGINE HOLD button 92

 Engine Oil 134

 ENGINE START/STOP button 93

 Entering a Destination 80

 Exterior lights 27, 35

 Fastening a Seat Belt 7

 Find Nearest Place 81

 Find Place Commands 152

 Flat Tire 120

 Floor Mats 41

 Fluids 147

 FM/AM Radio 55

 FM/AM Radio Commands 152

 Fog lights 27

 Foot Brake 98

 Forward Collision Warning (FCW) with Pedestrian Detection 25, 27, 102

 Frequently Asked Questions 148

 Front Airbags (SRS) 9

 Front Door Inner Handle 32

 Fuel Information 96, 114

 Fuse Locations 125

 Garage Opener 46

 Handling Information 3

 Hang-Up/Back button 67

 Hard Disc Drive (HDD) Audio 58

 Hard Disc Drive (HDD) Commands 152

 HDMI 64

 Headlight Washers 35

 Headlight-Wiper Integration 37

 Headphones 64

 Head Restraints 40

 Heated Steering Wheel 49

 Heated Windshield Button 49

 High beams 27

 Home Address 80

 HomeLink® Garage Opener 46

 Hood 133

 IDS 97

 Immobilizer 26

 INFO button 78

 Instrument Panel 24

 Condition Indicators 26

 Malfunction Indicators 24

 Multi-Information Display 28

 On/Off Indicators 27

 Integrated Dynamics System (IDS) 97

 Interface dial 54, 67, 78

 Interior Lights 36

 Intermittent Wipers 37

 iPod® 59

 iPod® Commands 152

 Jump Starting 115

 Keyless Access System 25, 30

 Lane Departure Warning (LDW) 25, 105

 Lane Keeping Assist System (LKAS) 25, 106

 Lap/Shoulder Seat Belts 5

 LATCH-Compatible Child Seat 18

 Light Bulbs 147

NAVIGATION

DRIVING

HANDLING THE UNEXPECTED

MAINTENANCE

SPECIFICATIONS

CLIENT INFORMATION

VOICE COMMAND INDEX

INDEX

Lights 27, 35

LINK button 76

Lock Tab 32

Low fuel 26

Low oil pressure 24

Low tire pressure 26

Maintenance 130

 Battery 137

 Engine Coolant 136

 Engine Oil 134

 Maintenance Minder™ 131

 Opening the Hood 133

 Service Codes 132

 Under the Hood 133

 Window Washer Fluid 137

 Wiper Blades 138

 Making a Call 70

 Malfunction indicator lamp 24

 Malfunction Indicators 24

 Map Display Commands 151

 Map Legend 82

 Master Door Lock Switch 32

 Maximum Load Limit 86

 MENU button 54, 67, 78

 Mirrors 42

 Moonroof 34

 Multi-Information Display 28

 Multi-View Rear Camera 110

 Navigation 77

 AcuraLink Real-Time Traffic™ 83

 Detour 83

 Display and Controls 78

 Entering a Destination 80

 Find Nearest Place 81

 Home Address 80

 Interface Dial Feedback 79

 Map Legend 82

 Place Category 81

 Routing 82

 Shortcuts 81

 Steering Wheel Controls 77

 Street Address 80

 System Guidance Volume 79

 Talk Button Tips 77

 Turn-by-Turn Directions 82

 Voice Prompt 79

 Navigation Commands 151

 On-Demand Multi-Use Display (ODMD) 54

 One-Touch Turn Signal 36

 On/Off Indicators 27

 Opening the Hood 133

 Operator Assistance 76

 Overheating 117

 Paddle shifters 95

 Pairing a Phone 69

 Pandora® 61

 Pandora® Commands 152

 Parking brake 26, 98

 Parking Sensor System 109

 Passenger Airbag Off Indicator 12

 Phone 69

 Phonebook 71

 PHONE button 67

 Phone Commands 151

 Pick-Up button 67

 Place Category 81

 Power Door Mirrors 42

 Power Mode 93

 Power Moonroof 34

 Power Tailgate 31

 Power Windows 33

 Rain-Sensing Wipers 38

 Readiness Codes 146

 Rear Camera 110

 Rear Climate Control 48

 Rear Cross Traffic Monitor 111

 Rear Entertainment System 63

 Rear Seats 44

 Rearview Mirror 42

 Rear Wiper 38

 Refueling 114

 Remote Battery Strength 115

 Remote Control 65

 Remote Engine Start 92

 Remote Transmitter 29

 Reporting Safety Defects 23

 Reverse Tilt Door Mirrors 42

 Road Departure Mitigation (RDM) 25, 107

 Roadside Assistance 150

 Route Commands 151

 Routing 82

 Safety Information 3

 Child Safety 15

 Important Handling Information 3

 Reporting Safety Defects 23

 Safety Label Locations 22

 Safety Messages 4

 Seat Belts 5

 Adjusting the Shoulder Anchor 7

 Fastening a Seat Belt 7

 Lap/Shoulder Seat Belts 5

 Seat Belt Inspection 6

 Seat belt reminder 26

 Seat Belt with Detachable Anchor 8

 Seat Heaters and Ventilation 50

 Seats 39

 Second-Row Seats 44, 45

 Selector wheel 28, 53, 67

 Sequential Mode 95

 Service Codes 132

Settings 51

SETTINGS button 54, 67, 78

Setting the Clock 51

SH-AWD 25

Shifting 94

 Electronic Gear Selector 94

 Sequential Mode 95

Shoulder Anchor 7

Side Airbags 10

Side Curtain Airbags 10

Siri® Eyes Free 74

SiriusXM® Radio 56

SiriusXM® Radio Commands 152

SMS Text Messaging 73

Song By Voice™ Commands 152

Sound 53

SOURCE button 53

Specifications 147

Speed Dial 71, 72

SRS (Supplemental Restraint System)

 Indicator 11, 25

Steering Wheel 43

Steering Wheel and Nearby Controls 1

Steering Wheel Controls 53, 77

Street Address 80

Super-Handling All-Wheel Drive 25

Surround View Camera 112

System Guidance Volume 79

System message 26

Tailgate 30

Talk button 67, 77

Talk Button Tips 68, 77

Text Messaging 73

Third-Row Seats 44, 45

Tire Information 140

 DOT Tire Quality Grading 144

 Tire and Loading Information Label 141

 Tire and Wheel Replacement 141

 Tire Chains 142

 Tire Identification Number 143

 Tire Labeling 143

 Tire Service Life 142

 Tire Terminology 143

 Winter Tires 142

Tire Pressure Monitoring System (TPMS)

 25, 118, 119

Tire Repair Kit 124

Tires 147

Towing a Trailer 88

 Load Limits 88

 Tongue load 89

 Trailer weight 88

Traffic 83

TRIP button 28

Troubleshooting 148

Turn-by-Turn Directions 82

Turn Signal 27, 36

Ultrawide Dual Screen 66

Under the Hood 133

USB Commands 152

USB Flash Drive 57

USB Port 52

Utility Vehicle 85

Vehicle Controls 29

Vehicle Specifications 147

Vehicle Stability Assist (VSA®) 25, 27, 97

Voice Command Index 151

Voice Prompt 79

Warranty Coverages 150

Window Washer Fluid 137

Windows 33

Winter Tires 142

Wiper Blades 138

Wipers 37

Wireless headphones 64

NAVIGATION

DRIVING

HANDLING THE UNEXPECTED

MAINTENANCE

SPECIFICATIONS

CLIENT INFORMATION

VOICE COMMAND INDEX

INDEX